

NLR Optical Switch Deployment

John Moore

jhm@mcnc.org

7/17/06

Overview

- The NLR Engineering committee started looking at deploying optical cross-connect switches about one year ago.
- Worked with Calient Networks and initiated a deal to purchase one switch short term, with options for more.
- The committee is currently working on coming up with a plan for installing and evaluating the utility of the Calient PXC platform.

Calient Networks PXC

- MEMS-based optical cross-connect (N by N matrix)
- GMPLS control plane capability
- Redundant, NEBS-compliant features available

Prioritized Goals

Use the PXC...

1. To enhance WaveNet fault tolerance. Understand how to utilize a spare wave to reduce downtime in an automated fashion.
2. As a demarcation point between NLR and a RON. Understand the issues associated with sharing management and control between organizations.
3. As a resource for researchers to experiment with GMPLS by providing access to the PXC control plane. Collaborate and interoperate with research projects focusing in this area (Enlightened, Cheetah, Dragon, etc.).

Resiliency

- Need two PXC's at minimum to test simple backup configuration
 - Partner with one or more groups that have PXC's (MCNC, LONI, Starlight, UL)
 - Can test partial path restoration (i.e. the user tributary doesn't need to be local to the user)
 - Switchover methods:
 - Manual and automated (via GMPLS)
 - Calient EMS (need more info...)
- Per Grover, this project can use any spare wave segments it requires

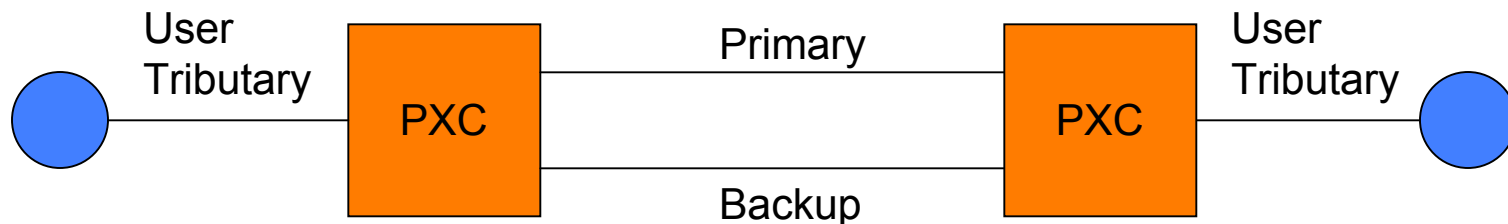

Resiliency (cont.)

- Second phase is to support real application (?)
 - Linda has suggested ETF. LONI wave is a possibility. Others?
 - NLR's PXC has redundancy features
 - Of other PXC's, only LONI's is fully redundant
 - Will require second NLR PXC?
- *Two examples:*

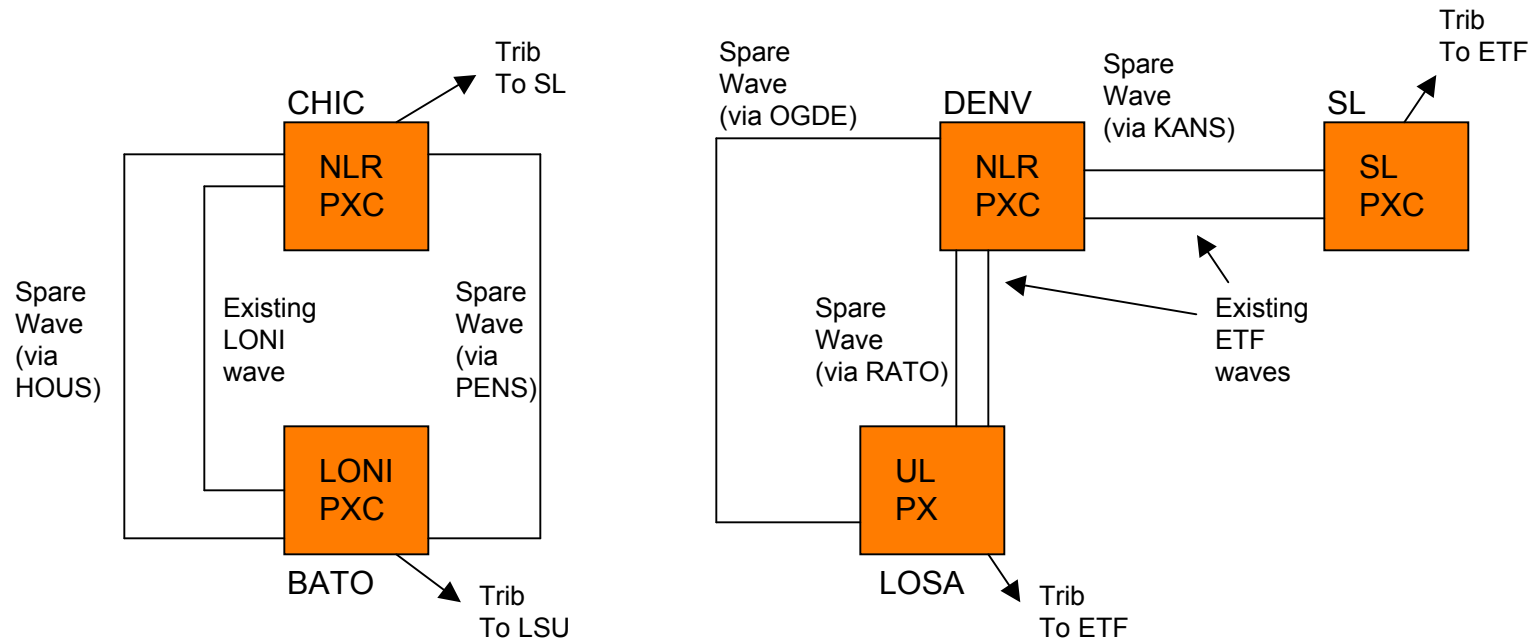

Alternatives

(for reference, from 6/20 NLR-ENG meeting)

	<i>WASH</i>	<i>CHIC</i>	<i>ATLA</i>	<i>DENV</i>	<i>HOUS</i>
Space/power?	Yes, plenty	One rack available, difficult to get to. Power OK	Space in SLR Courtland St suite, use SLR waves to connect to 56 Marrietta	No good space, power marginal	Yes, plenty
Three-way junction?	Yes	Yes	Yes (with ORNL waves)	Yes	Yes
Potential existing connections?	Break NLR 107 (Enlightened)	Break NLR 107, NLR 57 (LONI) and Caltech FrameNet	Utilize ORNL wave(s)	Spare wave (STAR-LOSA) Break Caltech FrameNet	Break NLR 57
Collaboration opportunities?	MAX/Dragon Enlightened	CIC Enlightened	SLR Cheetah	FRGP/UCAR	LEARN Enlightened

Call for Proposals

- The NLR Engineering committee will be issuing a call for proposals to partner with NLR on this project
- Audience is NLR member organizations
- Proposals should focus on prioritized goals, details about local collaboration potentials