



VINI: Virtual Network Infrastructure

Andy Bavier

Princeton University



<http://www.cs.princeton.edu/~acb>

Joint with Nick Feamster, Larry Peterson, Jennifer Rexford



VINI: A research testbed

- Server-class PCs installed in network PoPs
- Provide *slices* to network researchers
 - Virtual machines connected by a virtual network
 - Reserved resources (CPU, bandwidth)
- Useful for **long-term deployment studies**



- Demonstrate:
 - Robustness, scalability, security
 - Integration with other network systems
 - Real users → potential market!

Overview



- VINI vision
- Current status of VINI
- Future challenges



Fixed Infrastructure

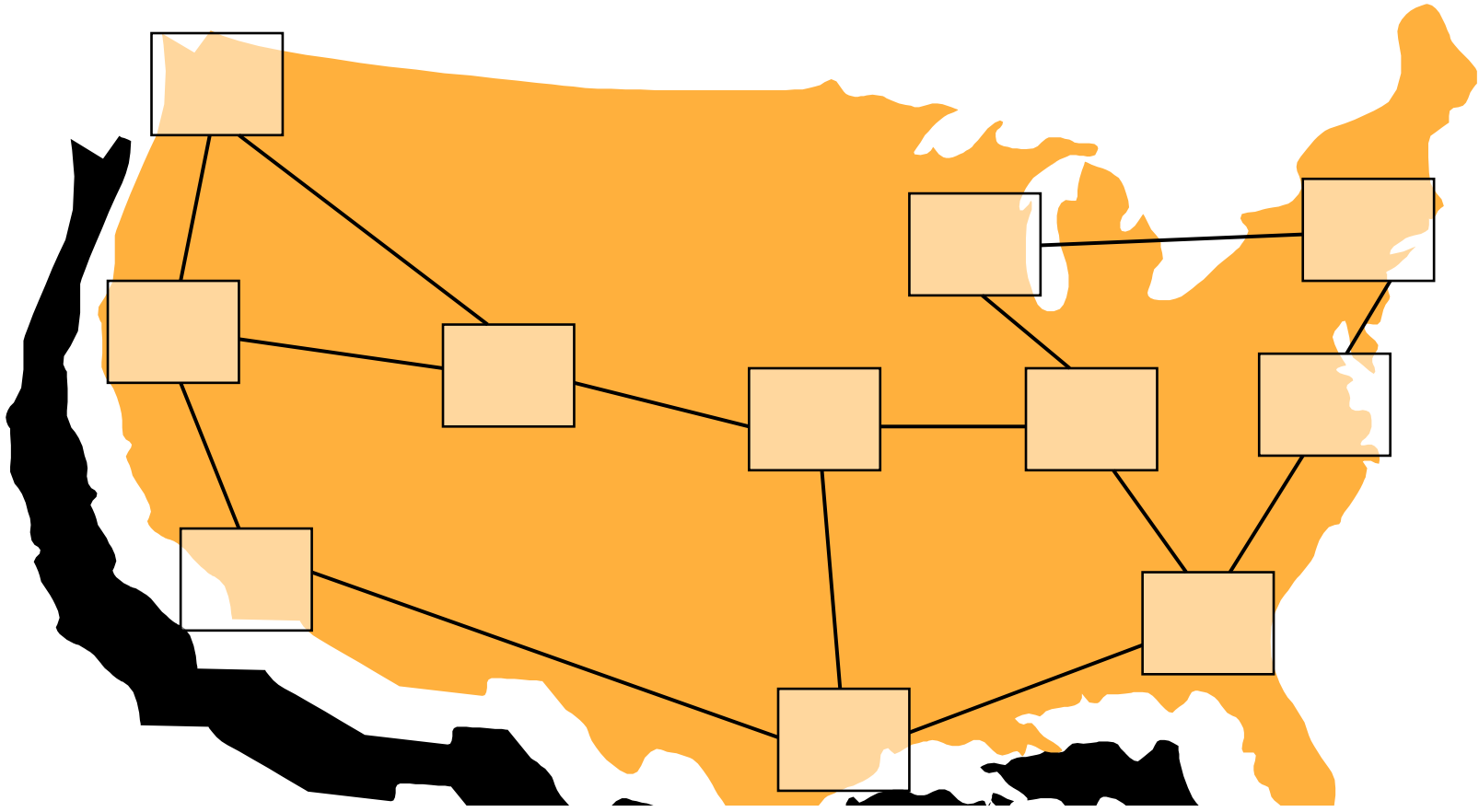

*VINI nodes in National LambdaRail, Internet2,
PoPs in Seattle and Virginia, CESNET*



Shared Infrastructure

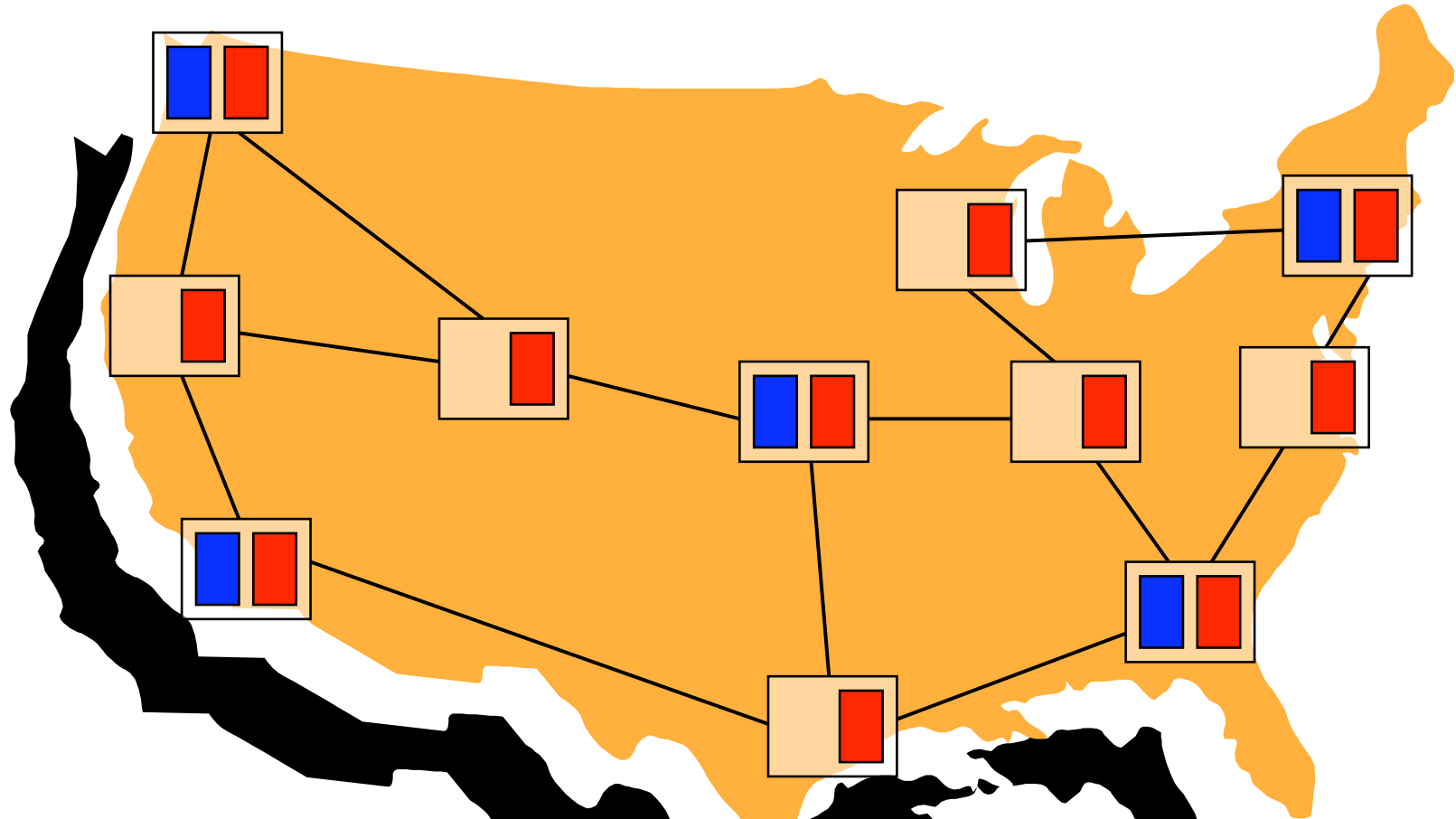

Experiments given illusion of dedicated hardware



Flexible Topology

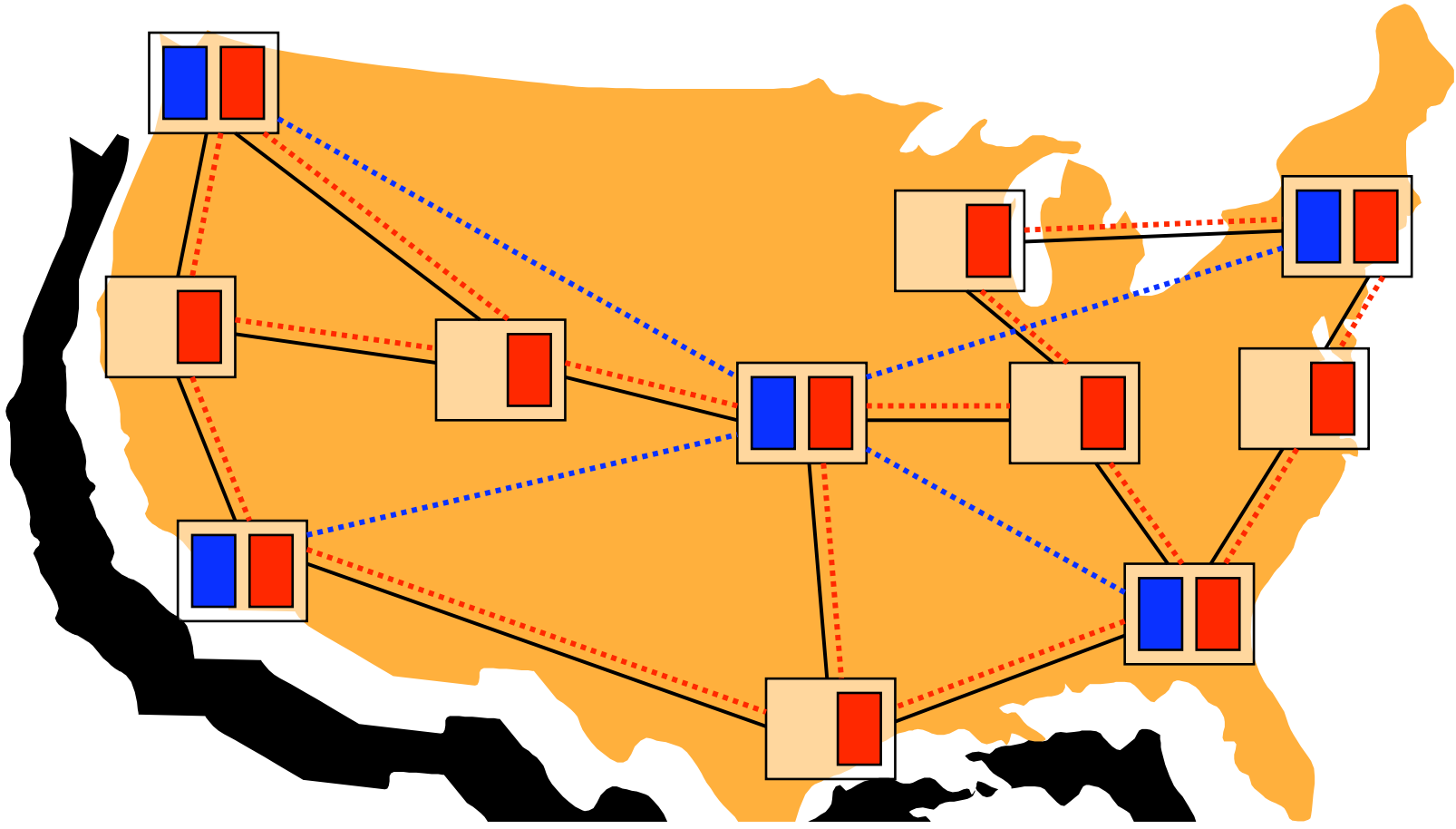

VINI supports arbitrary virtual topologies



Network Events

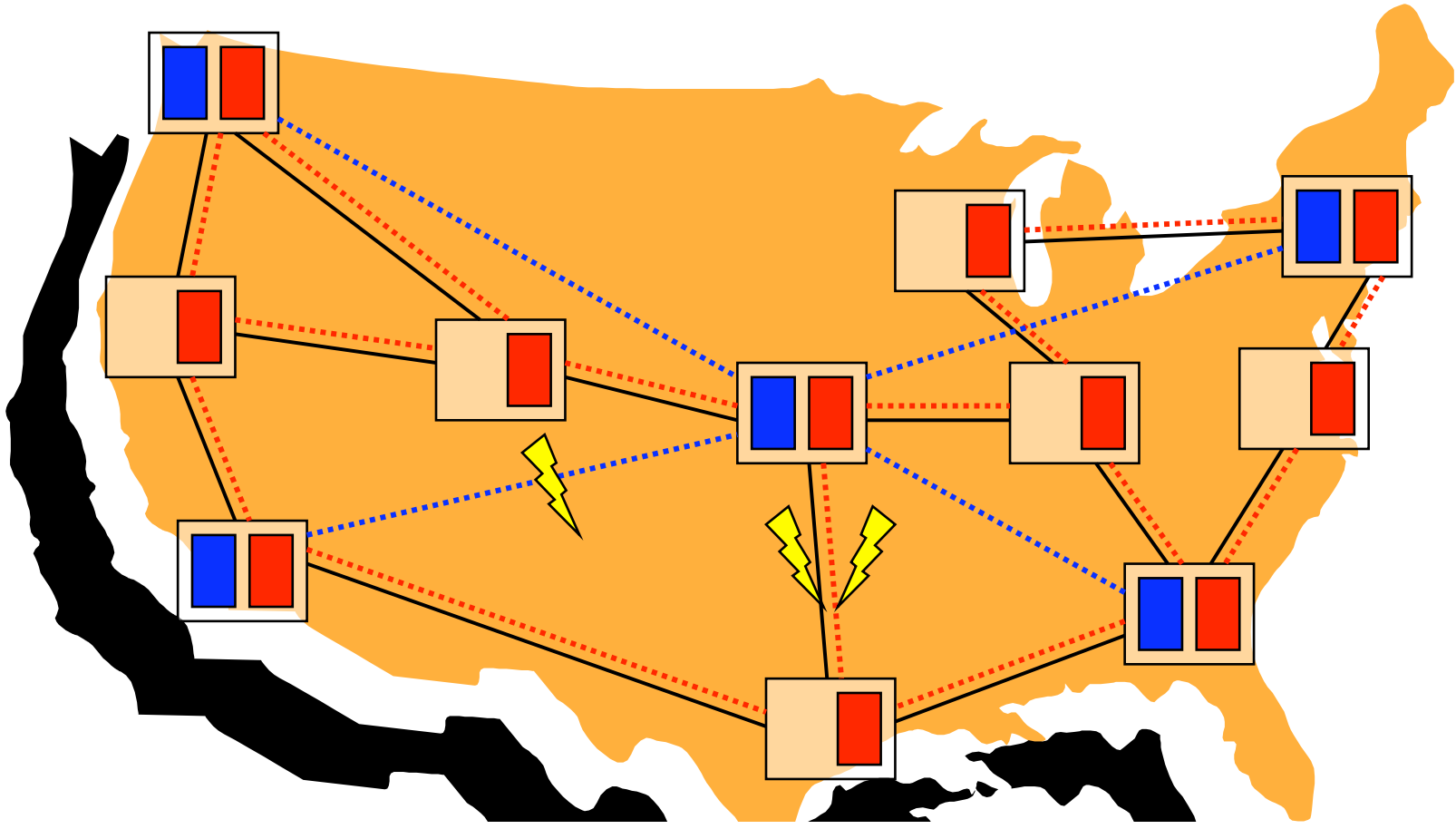

VINI exposes, can inject network failures



External Connectivity

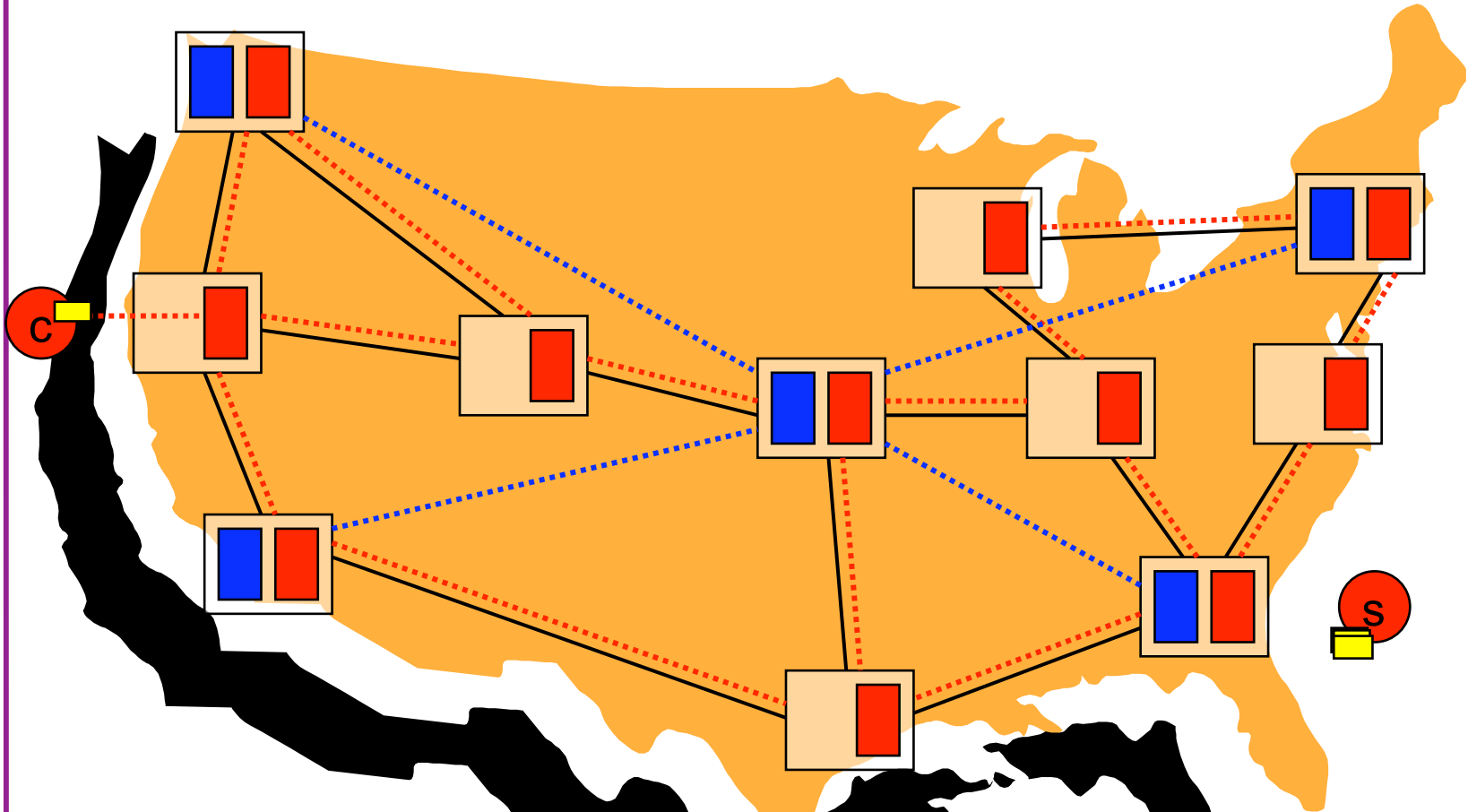

Experiments can carry traffic for real end-users



External Routing Adjacencies

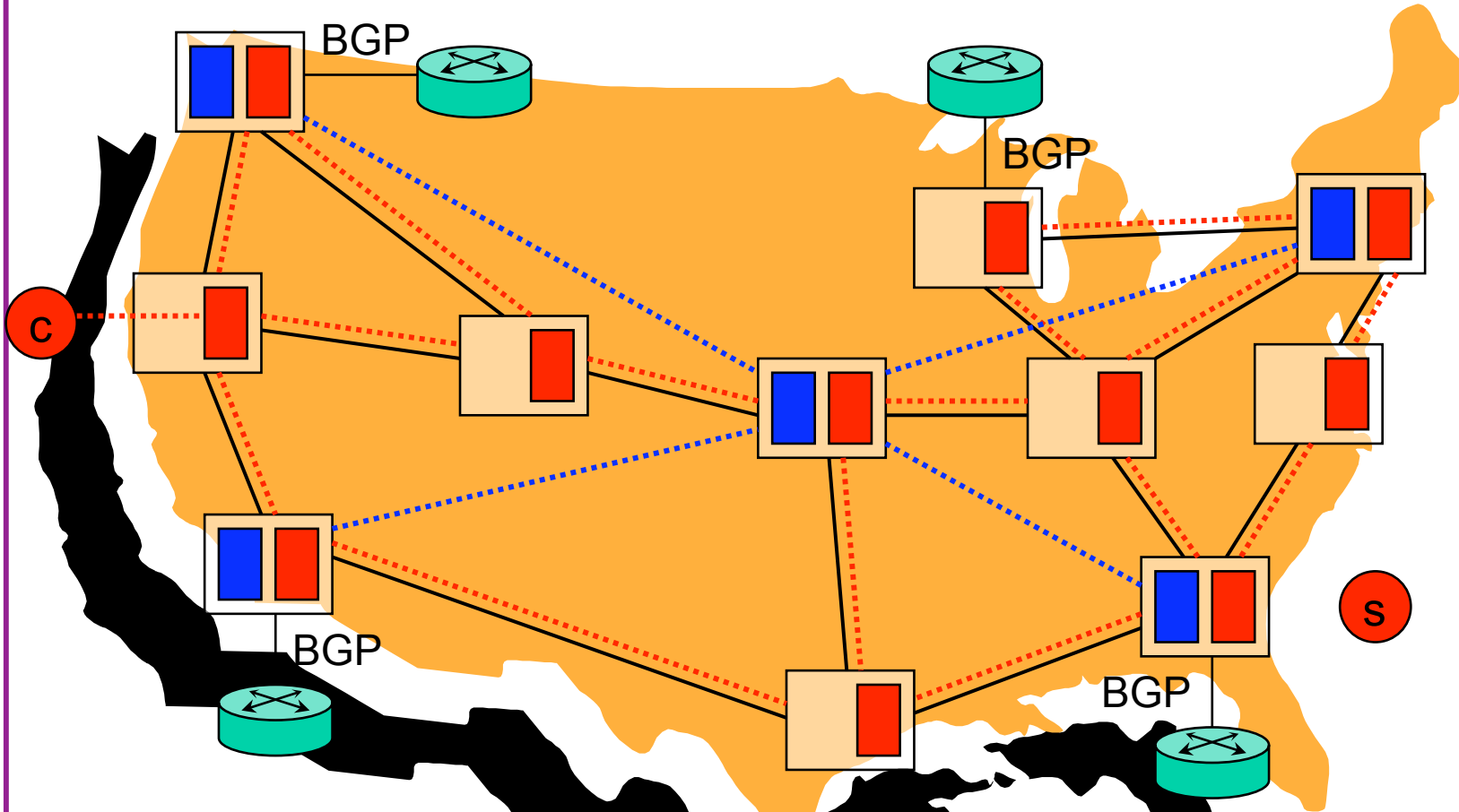

Experiments can participate in Internet routing

Overview



- VINI vision
- ***Current status of VINI***
- Future challenges

VINI Current Status - Deployment



- **Operational sites**
 - 7 National LambdaRail sites
 - 9 Internet2 sites
 - Westin in Seattle, WA
 - Equinix in Ashburn, VA
 - CESNET: Prague and Pilsen
 - 1Gb/s lightpath between Prague and VINI
 - Internet2 Chicago site
- **Two VINI nodes per site**



VINI Status - Virtual Hosts

- VINI based on *PlanetLab* software
 - Simultaneous experiments in separate VMs
 - Each has “root” in its own VM, can customize
 - Reserve CPU and bandwidth per experiment

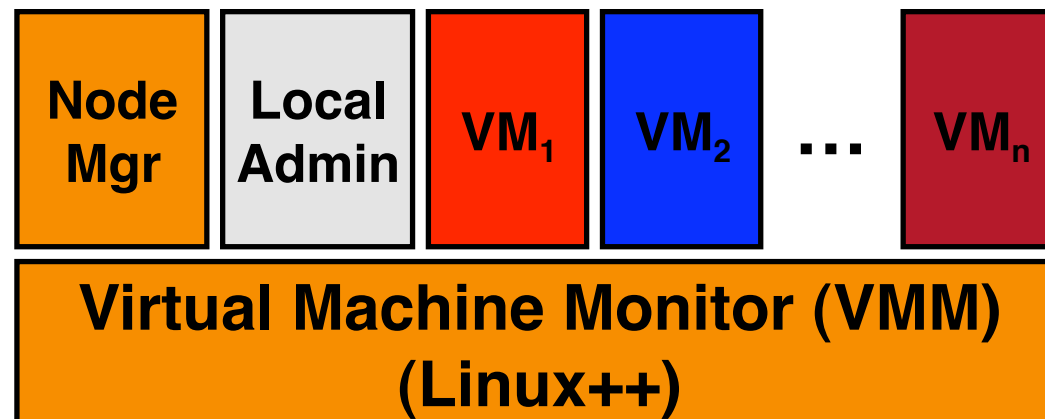

PlanetLab node



VINI Status - Virtual Networks

- Configure a *virtual topology* for a slice
 - Point-to-point virtual Ethernet links
 - Control routing table, virtual devices within the virtual hosts
- Can experiment with routing software (e.g., XORP, Quagga) that runs on Linux



VINI Trellis v0.1

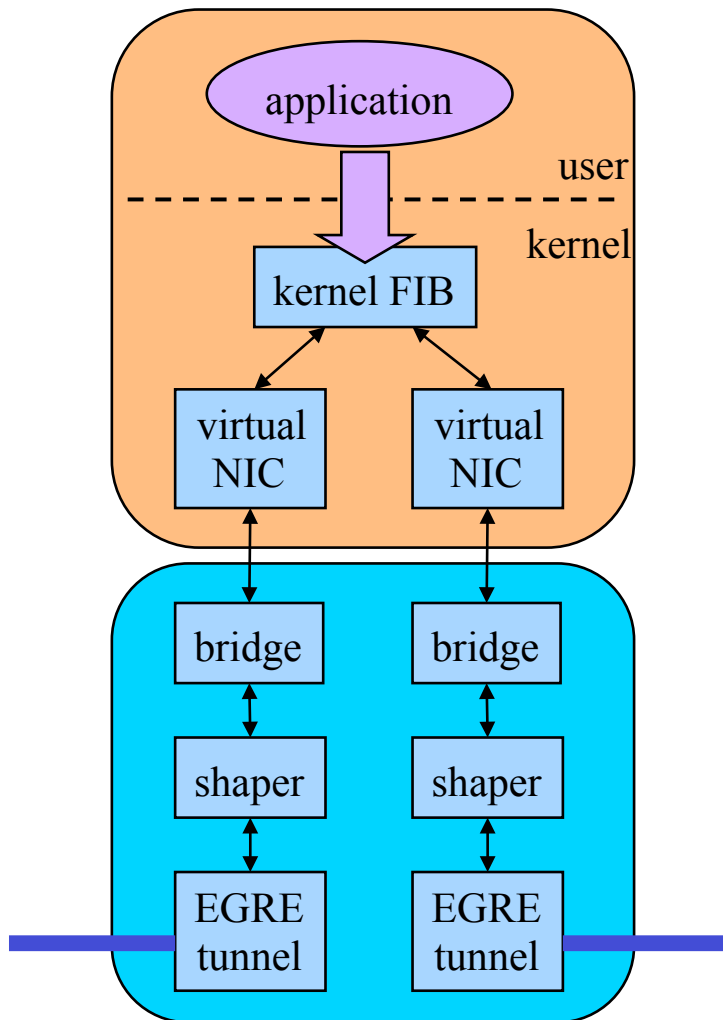

Virtual host

- Linux kernel IPv4 routing table
- Point-to-point virtual Ethernet
- Applications add/change routes

Substrate

- Ethernet software bridge
- Traffic shaper
- Ethernet-over-GRE tunnels
(to span multiple IP hops)

Overview



- VINI vision
- Current status of VINI
- ***Future challenges***



Future Questions for VINI

- How to leverage other testbeds?
- How to connect a VINI networking experiment to the “real world”?
- How can VINI have the widest impact?



Leveraging other testbeds

- *Federate with PlanetLab, OneLab, Emulab*
 - Create experiments that span multiple testbeds
 - Move experiments from one testbed to another
- **Long term: define general interfaces**
 - Advertising resources
 - Specifying resources
 - Authenticating users
 - Creating, deleting, and managing slices
- **Short term: adopt the best tools**
 - Emulab's topology creation (GUI, ns2 specification)

Connecting to the world



- Getting real routing information
 - BGP Multiplexer service
 - Receive BGP information from real routers
 - Some day: advertise routes, become “ISP”
- Getting real traffic
 - Deploy wireless access points
 - Hide behind a proxy (e.g., game server)
 - Leverage existing PlanetLab services (e.g., CDN)



Having a wide impact

- We want to grow the public VINI
 - CESNET deployment
- Enable others to create their own VINIs
 - Based on MyPLC software from Princeton
 - MyVINI = MyPLC + VINI kernel, tools
 - Development platform or dedicated testbed
- Federate with other VINI deployments!



Conclusion

- VINI is a platform for *deployment studies* of network research ideas
- Public VINI nodes in Internet2, NLR
 - Can create virtual networks of VMs
- VINI is based on MyPLC distribution, software is freely available

<http://www.vini-veritas.net>