

QoS Amplification Experiments

Kihong Park
Network Systems Lab
Dept. of Computer Sciences
Purdue University
park@cs.purdue.edu

<http://www.cs.purdue.edu/nsl>

Overview

Goal Achieve QoS amplification over imperfect network service substrate

→ end-to-end control

- ◆ End-to-end QoS amplification techniques
 - Multiple time scale traffic control
 - Adaptive redundancy control
 - Adaptive label control
- ◆ Internet2 experiments
 - Local environment
 - Internet2 requirements
 - Proposed WAN experiments and collaborations

Outline



Multiple Time Scale Traffic Control

Self-similar Network Traffic

- ◆ Data traffic is fundamentally different from telephony traffic (Leland *et al.* '93)
 - non-Markovian (e.g., Poisson)
 - self-similar or long-range dependent
- ◆ Causality
- ◆ Performance Impact
 - detrimental
 - polynomial vs. exponential queue length distribution

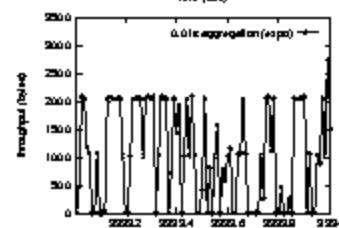
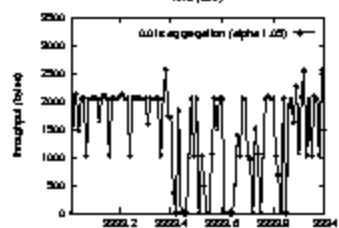
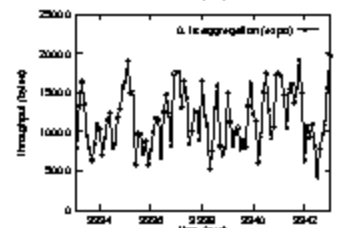
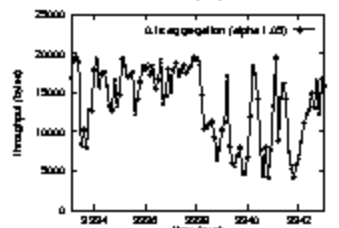
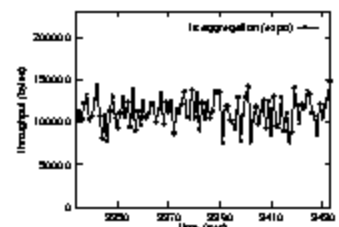
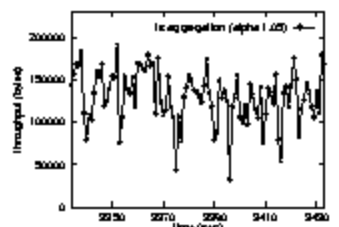
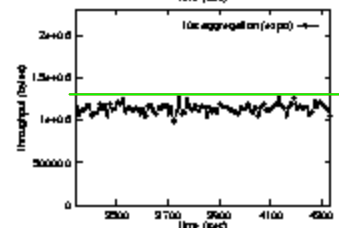
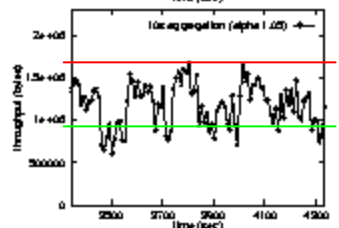
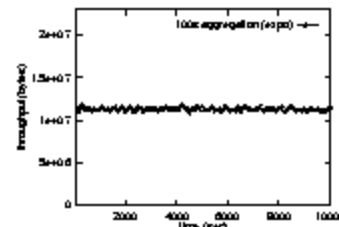
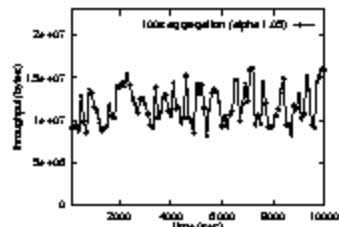

Multiple Time Scale (cont.)

- ◆ Causality
 - Single-source causality (e.g., MPEG video)

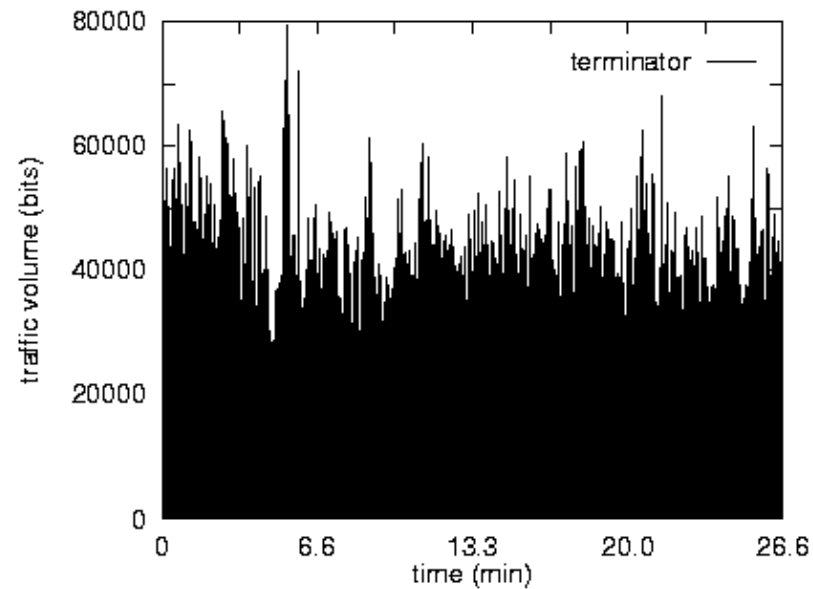

Multiple Time Scale (cont.)

- Structural causality

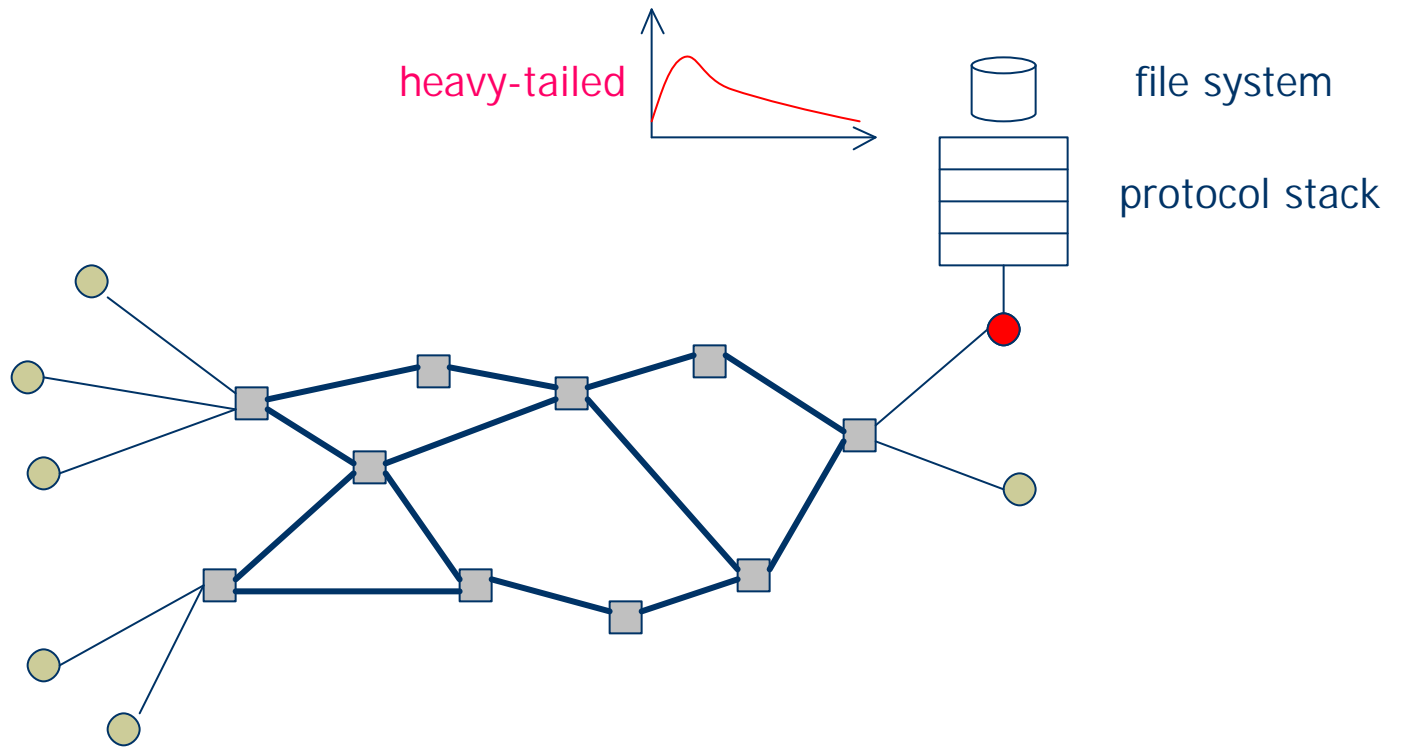

Multiple Time Scale (cont.)

- Structural causality (cont.)

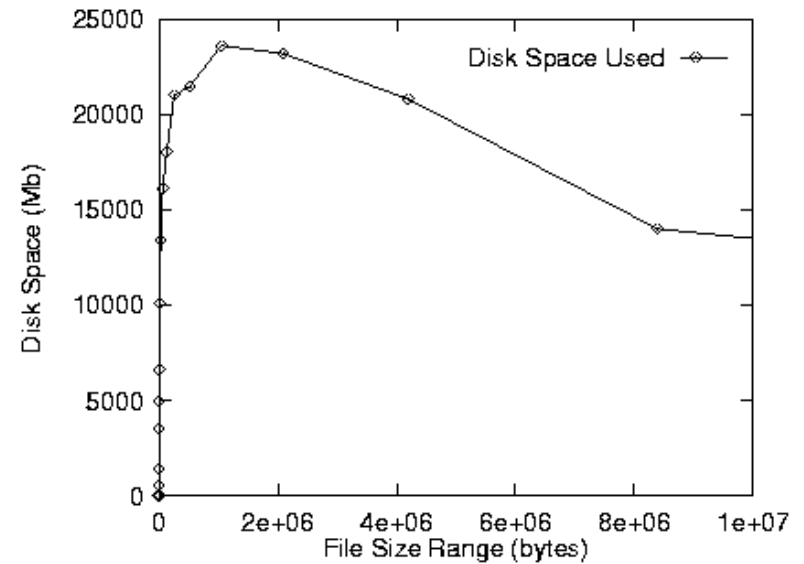
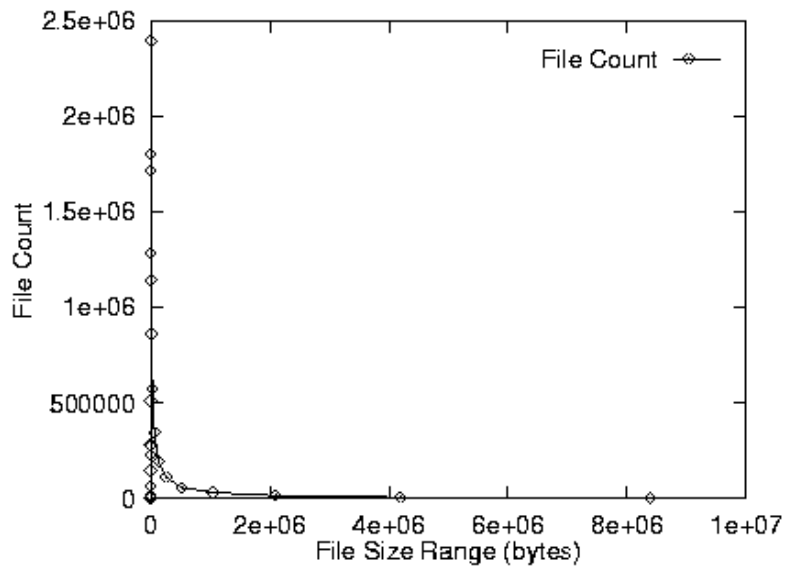

→ UNIX file system (G. Irlam)

Multiple Time Scale (cont.)

- Structural causality (cont.)

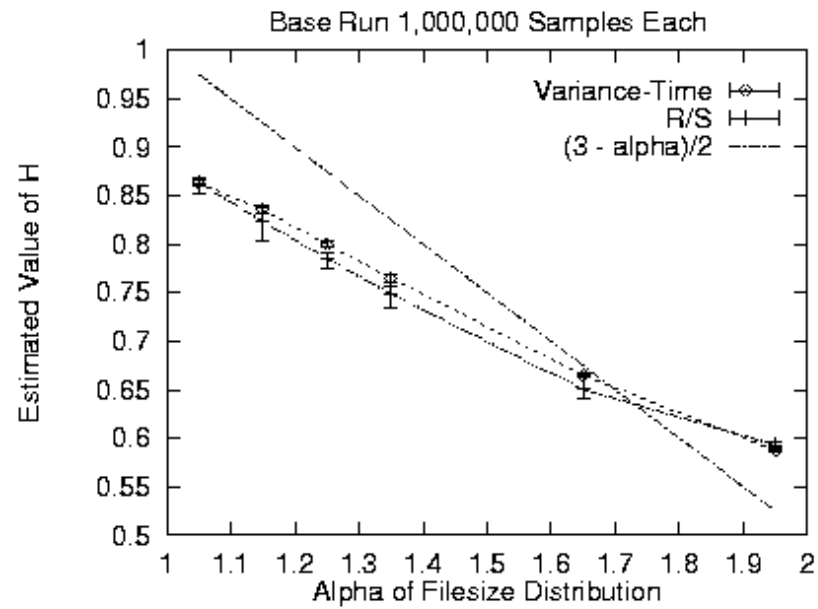

→ impervious to “details”

Multiple Time Scale (cont.)

- Structural causality (cont.)

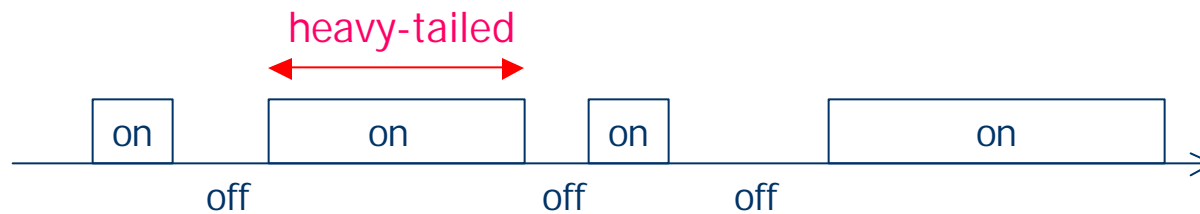

- on/off traffic (0/1 reward renewal process)
 - asymptotic second-order self-similarity
- Two principal traits
 - Invariant correlation structure across multiple time scales
 - Correlation at a distance (long-range dependence)

Multiple Time Scale (cont.)

- ◆ Detrimental performance impact: queueing

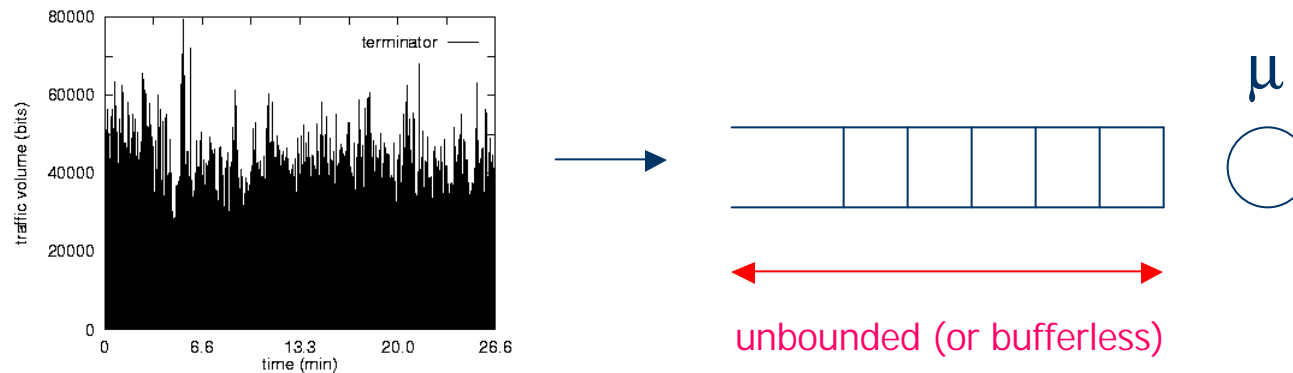

- polynomial (vs. exponential) queue length distribution
- infinite memory/asymptotic analysis

Multiple Time Scale (cont.)

◆ Empirical validation

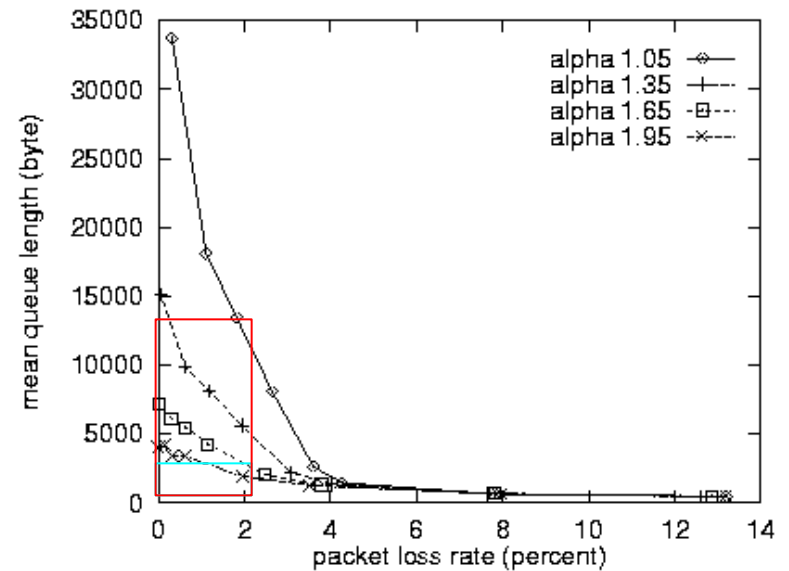
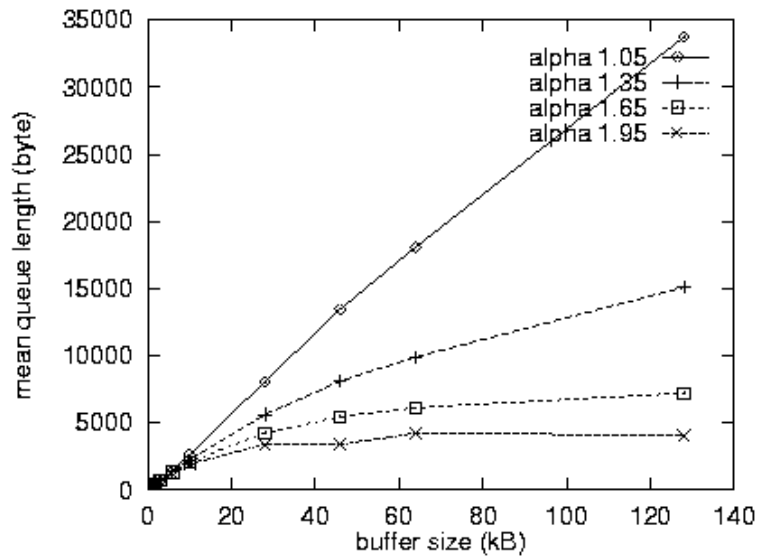
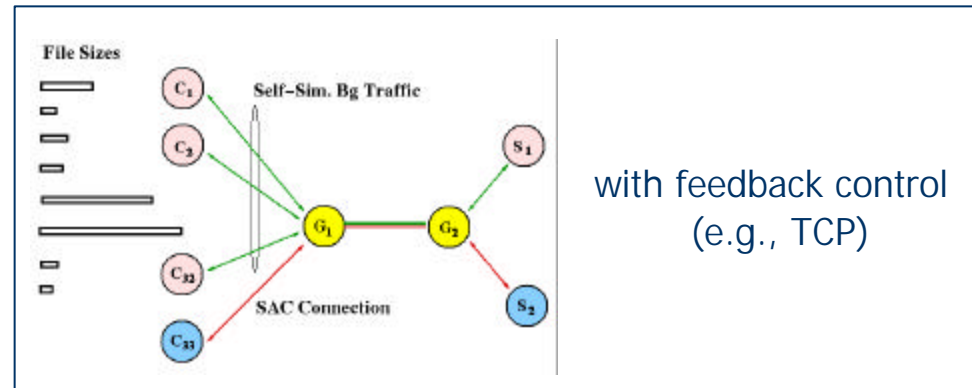



Multiple Time Scale (cont.)

- ◆ Impact of long-range structure can be curtailed
 - extreme: **bufferless** queueing
 - time horizon implied by finite memory
 - short-range correlation can dominate
- ◆ Small buffer/large bandwidth resource provisioning policy
 - statistical multiplexing
 - central limit theorem

Multiple Time Scale (cont.)

- ◆ Importance of second-order performance measures
→ e.g., jitter

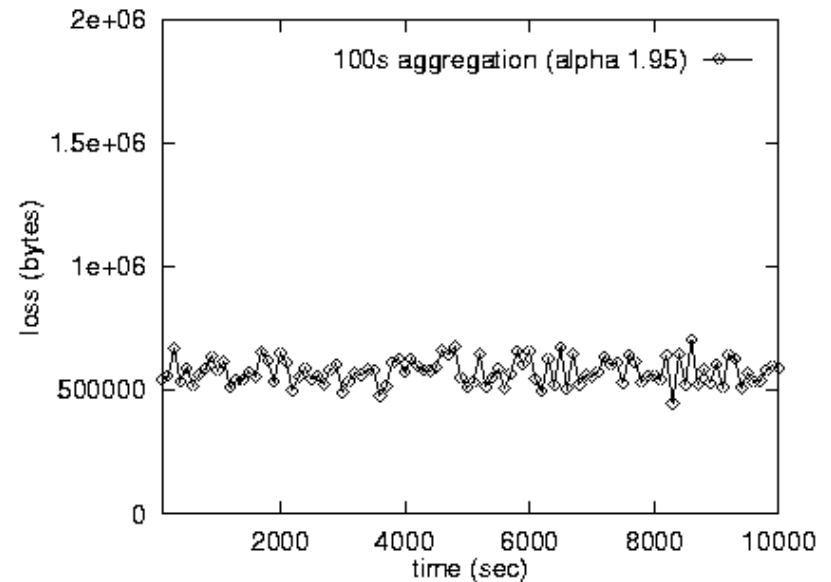
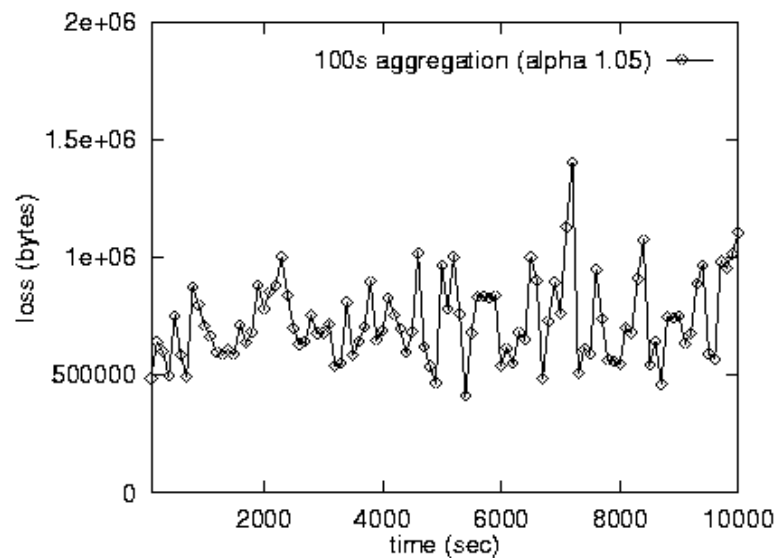

- concentrated periods of over- and under-utilization
- bufferless queueing does not help

Multiple Time Scale Traffic Control (cont.)

Traffic Control

- ◆ Premise: exploit long-range correlation for traffic control
 - correlation/predictability structure at large time scales

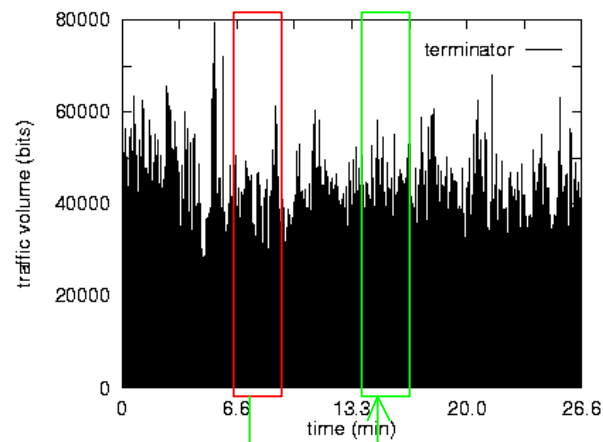

- relevant in broadband WANs with high delay-bandwidth product

Multiple Time Scale Traffic Control (cont.)

- ◆ Mitigate reactive cost of feedback control:

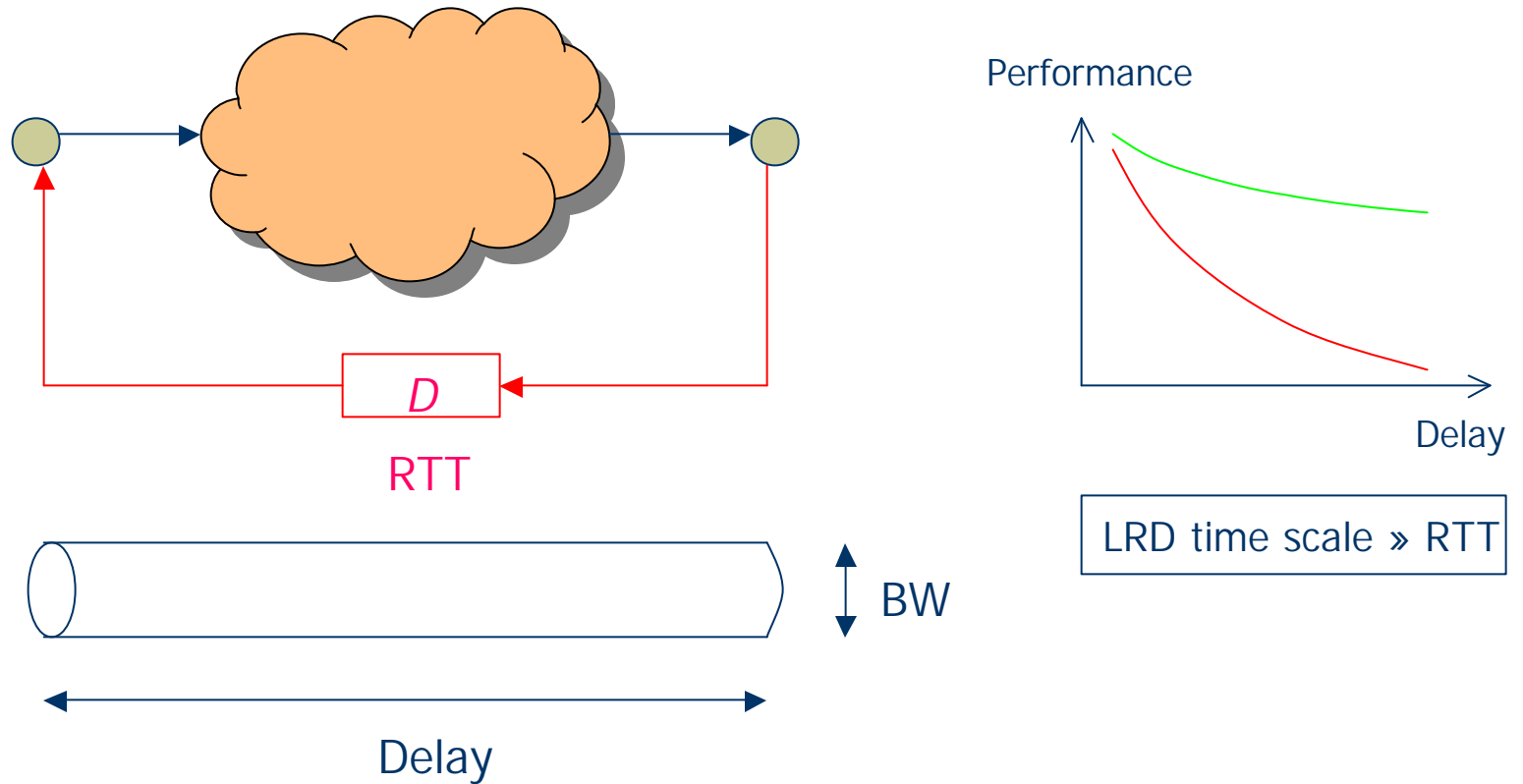

Multiple Time Scale Traffic Control (cont.)

Large time scale predictability:

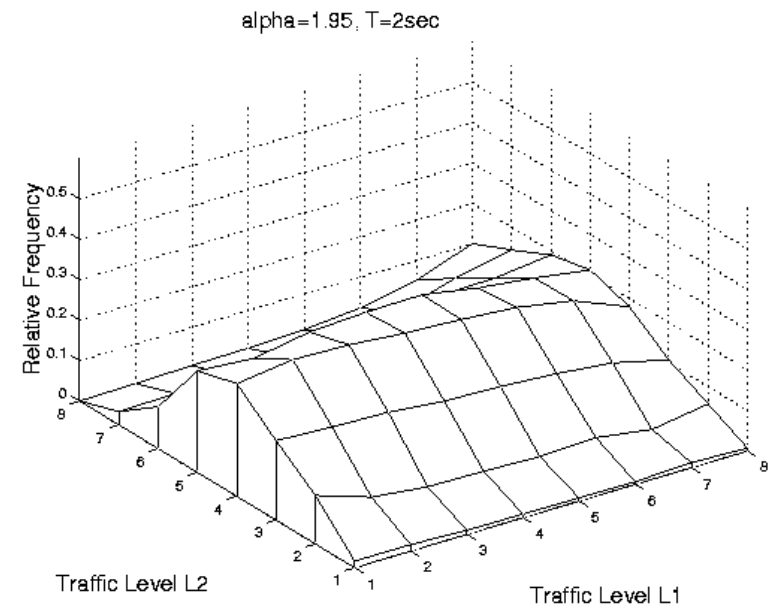
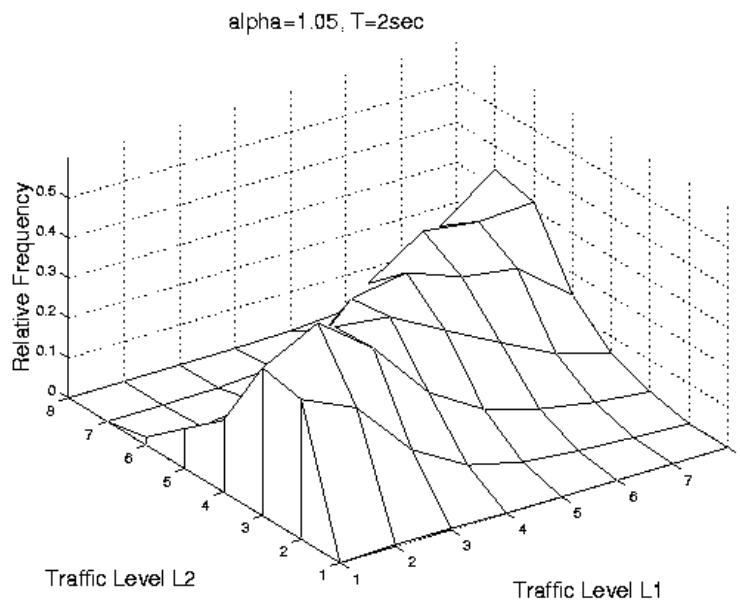
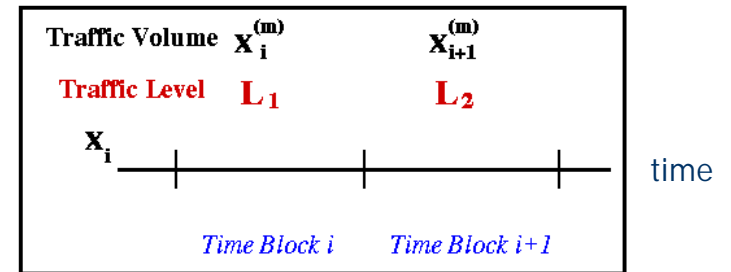

Multiple Time Scale Traffic Control (cont.)

Large time scale predictability (5 sec):

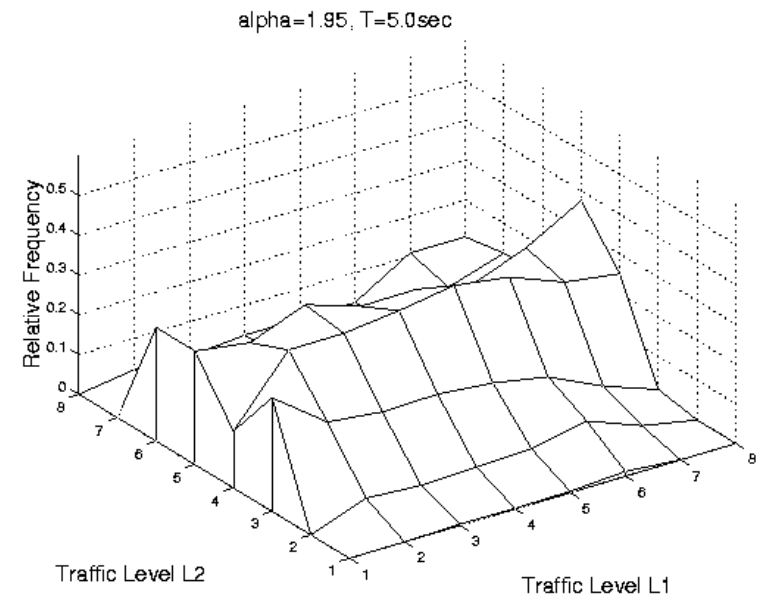
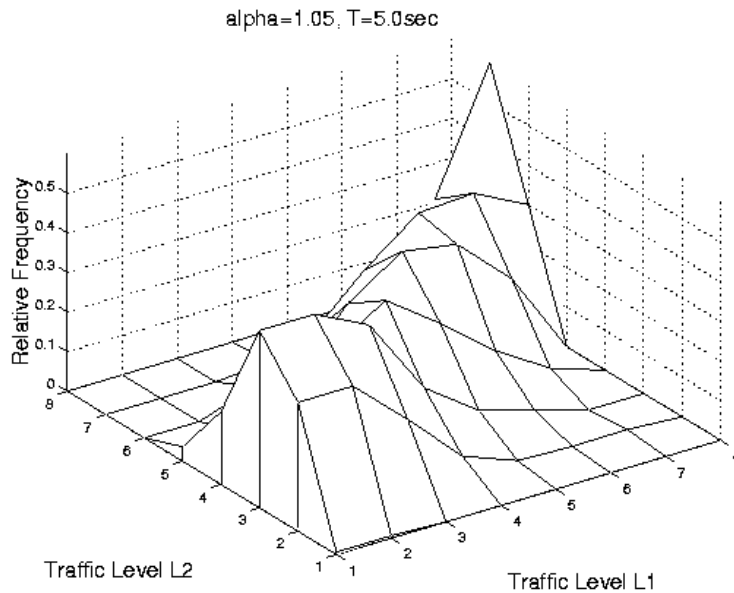

Multiple Time Scale Traffic Control (cont.)

Multiple time scale traffic control:

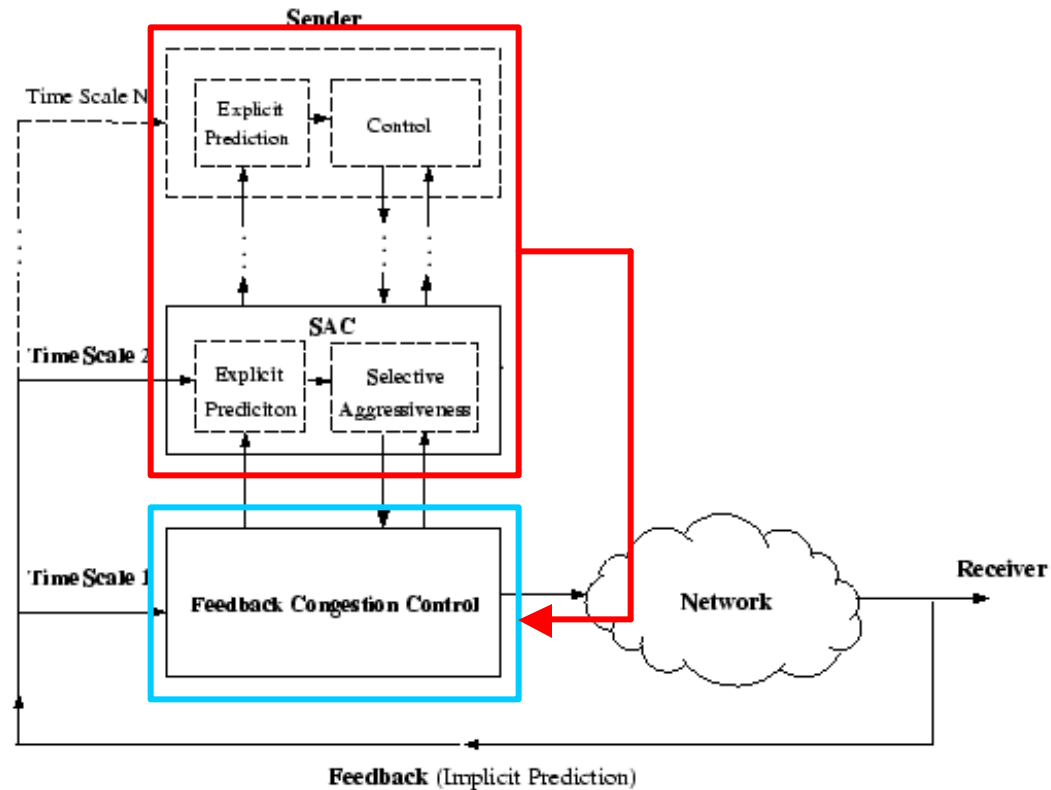



Multiple Time Scale Traffic Control (cont.)

Application domains:

- Bulk data transport – congestion control
 - throughput maximization (TCP-MT)
- Real-time data transport – adaptive redundancy control
 - end-to-end QoS (AFEC-MT)

Multiple Time Scale Traffic Control (cont.)

Congestion control: TCP and rate-based

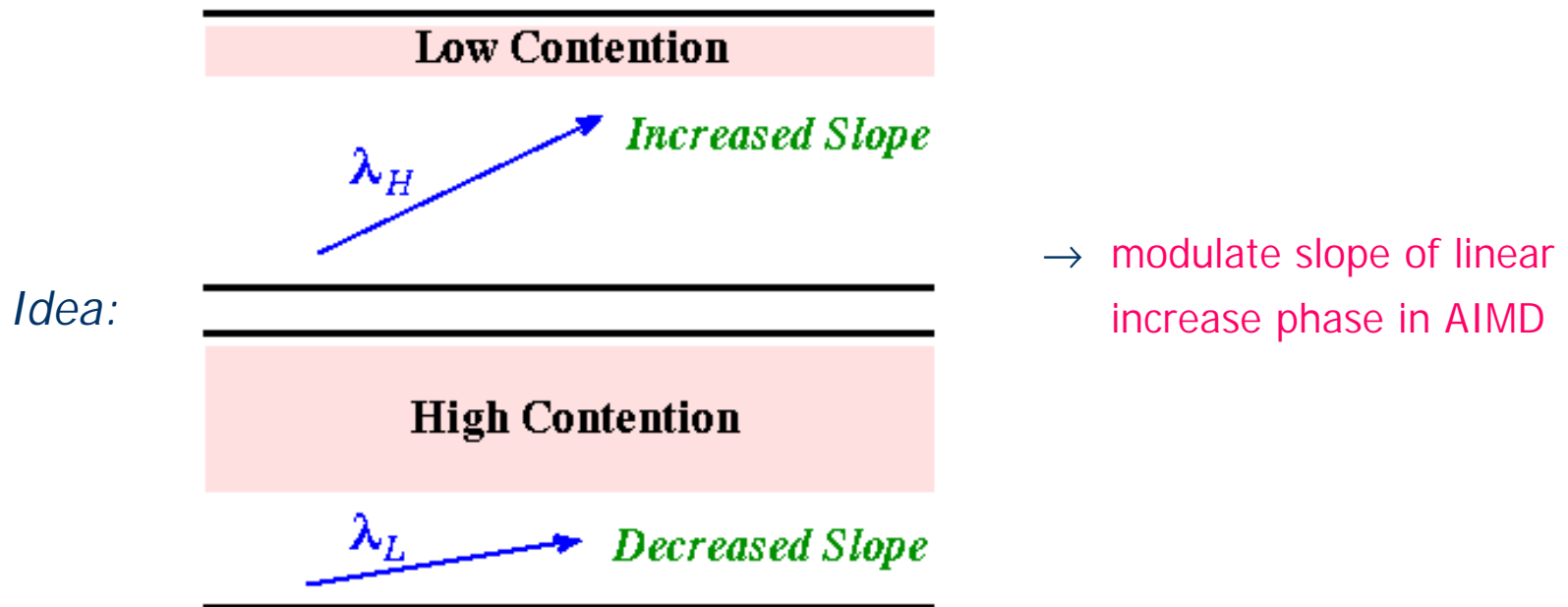

Multiple Time Scale Traffic Control (cont.)

- ◆ Multiple time scale TCP (TCP-MT):

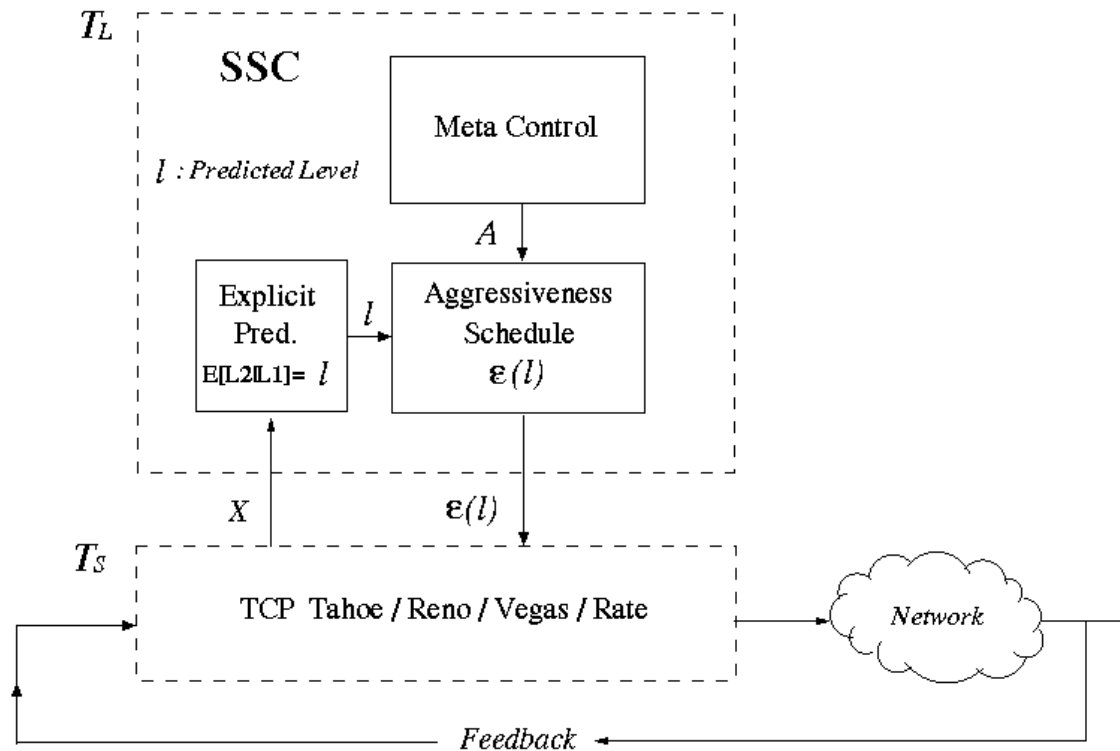

Multiple Time Scale Traffic Control (cont.)

- Multiple time scale rate-based congestion control:

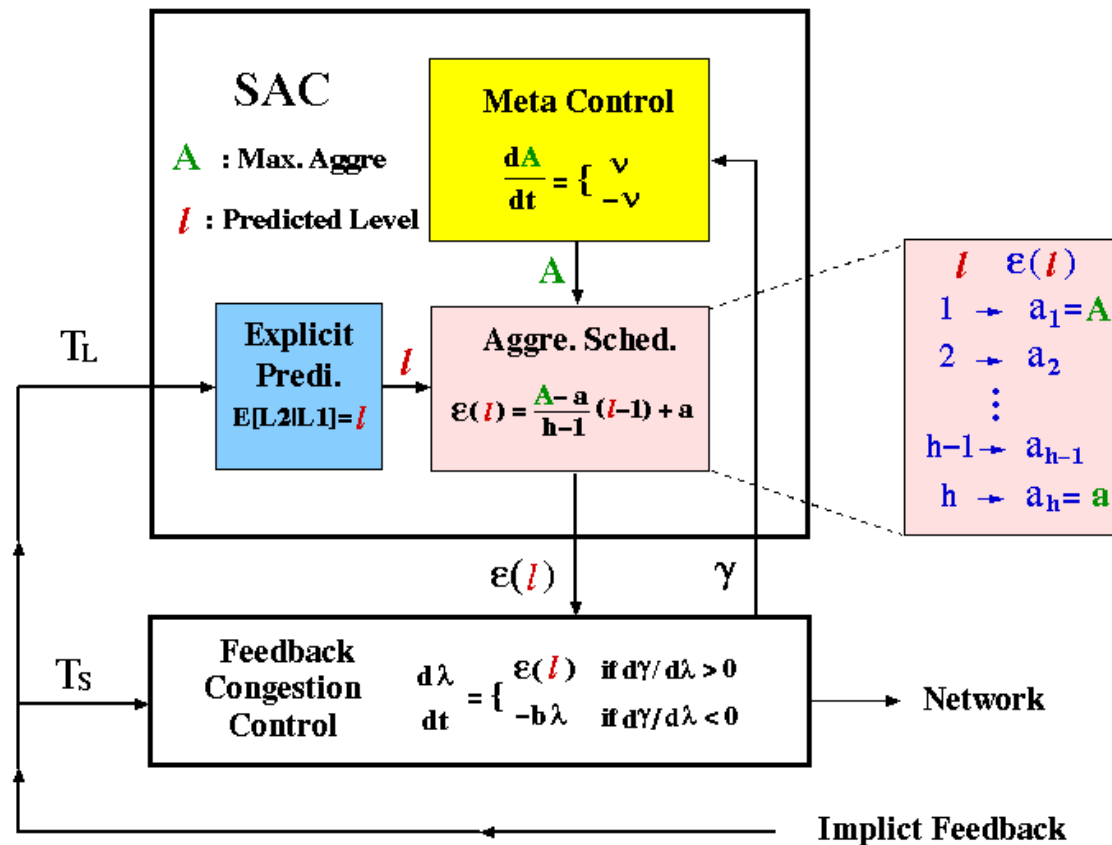

Multiple Time Scale Traffic Control (cont.)

- ◆ TCP-MT: performance gain as function of RTT

TCP-MT
TCP

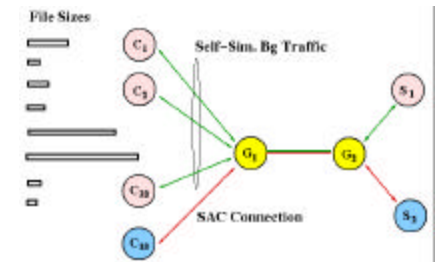
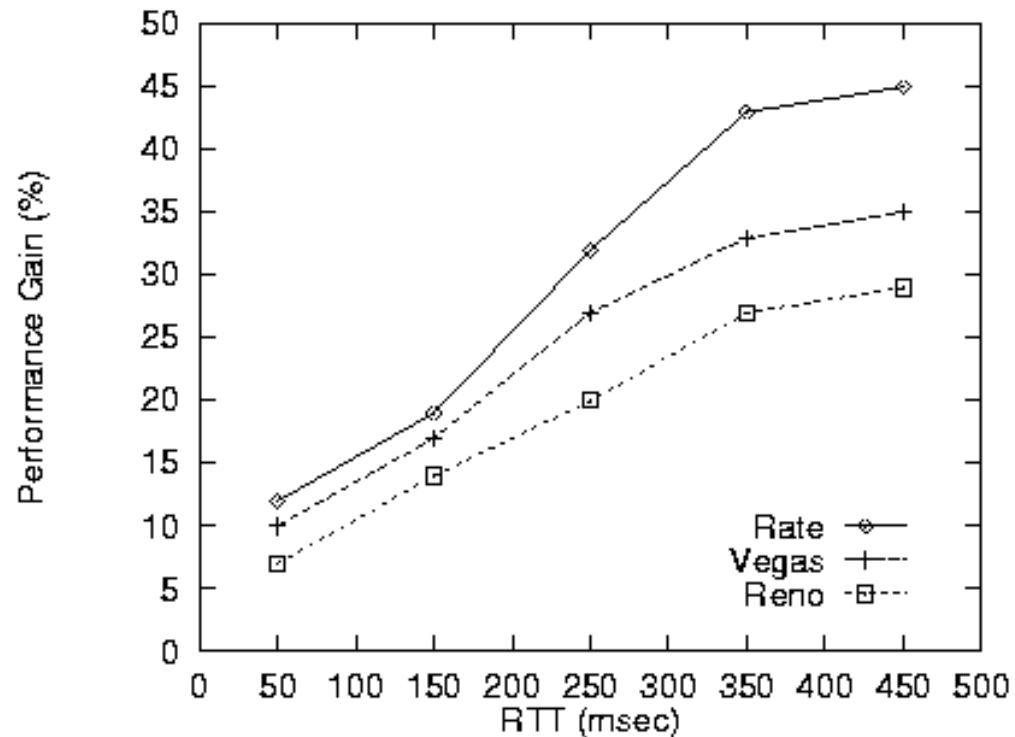

Multiple Time Scale Traffic Control (cont.)

- ◆ TCP-MT: performance gain as function of self-similarity

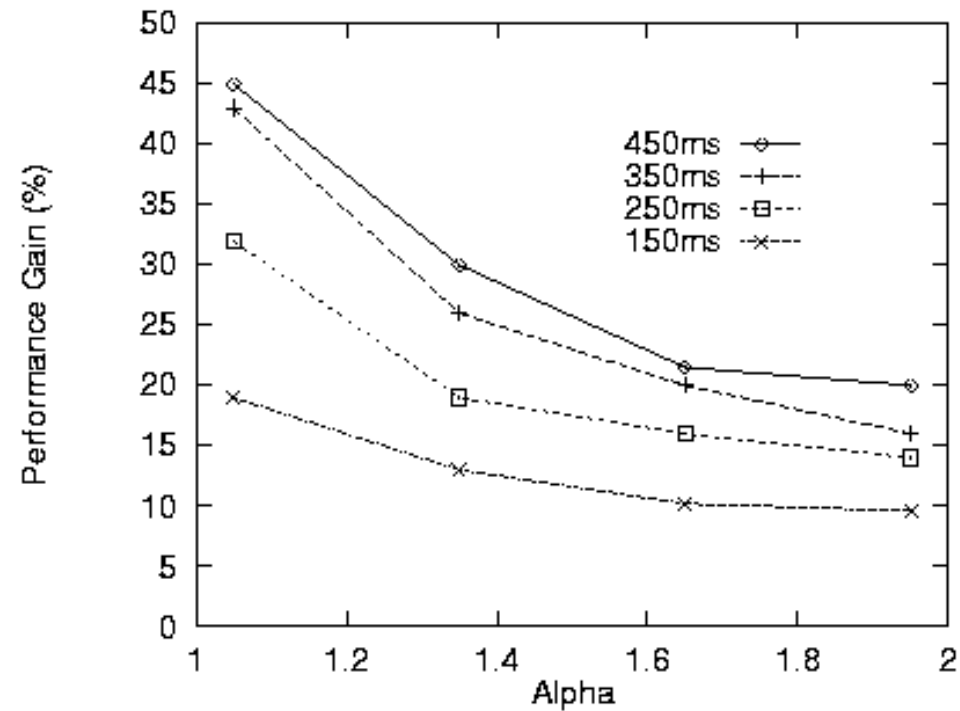



Adaptive Redundancy Control

Real-time traffic transport

- Achieve invariant end-to-end QoS
- User-specified QoS
- ARQ infeasible (RTT & timeliness)
- Packet-level FEC
 - proactive QoS protection
- Purely end-to-end (black box network)
- MPEG video/audio implementation (UDP)

Adaptive Redundancy Control (cont.)

Adaptive redundancy control (AFEC):

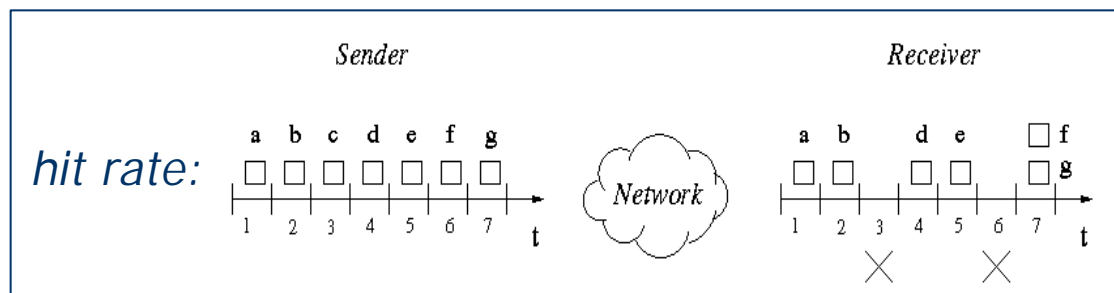
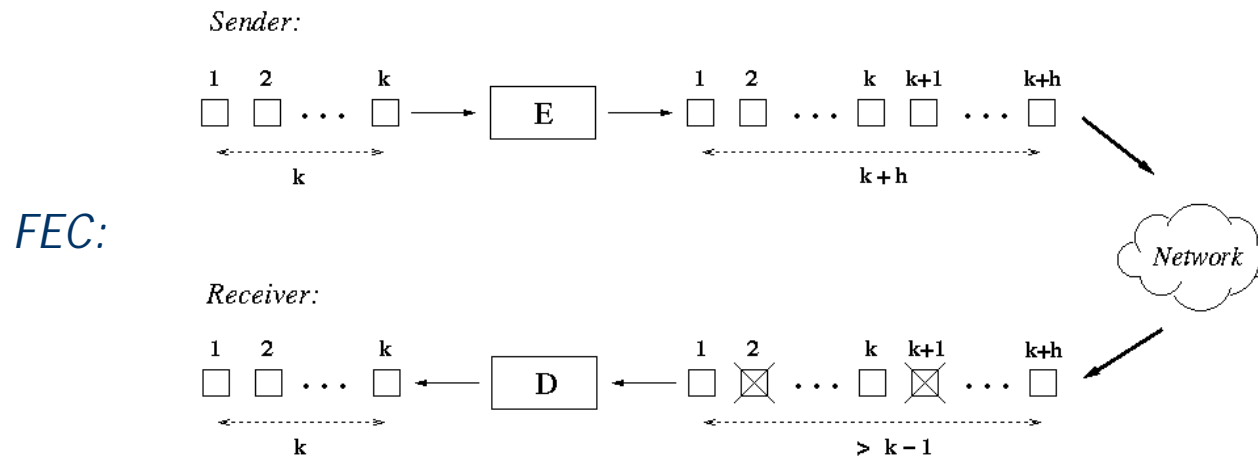

$$0 \leq \gamma \leq 1$$

Adaptive Redundancy Control (cont.)

- ◆ Redundancy-recovery relation:

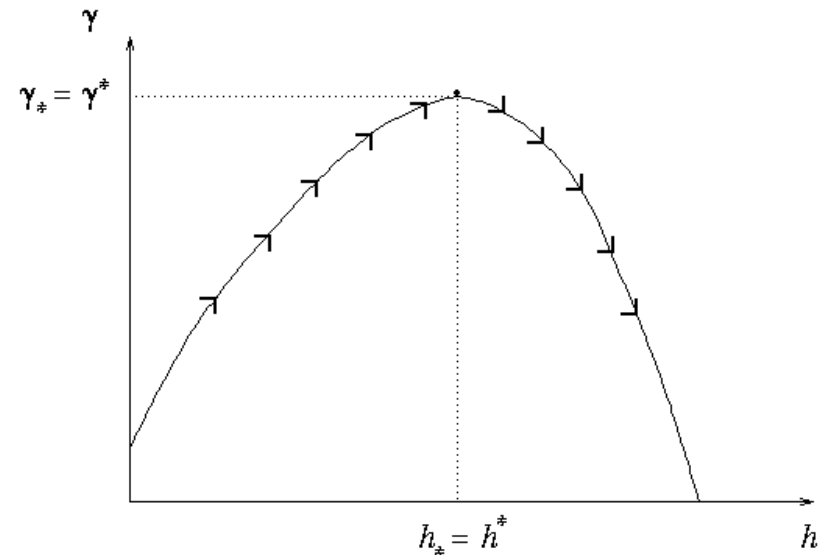
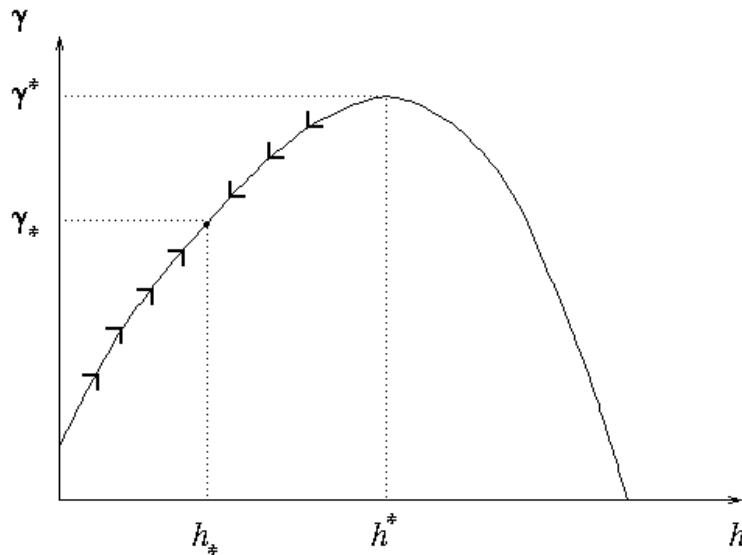

→ stability & optimality

Adaptive Redundancy Control (cont.)

- ◆ AFEC structure:

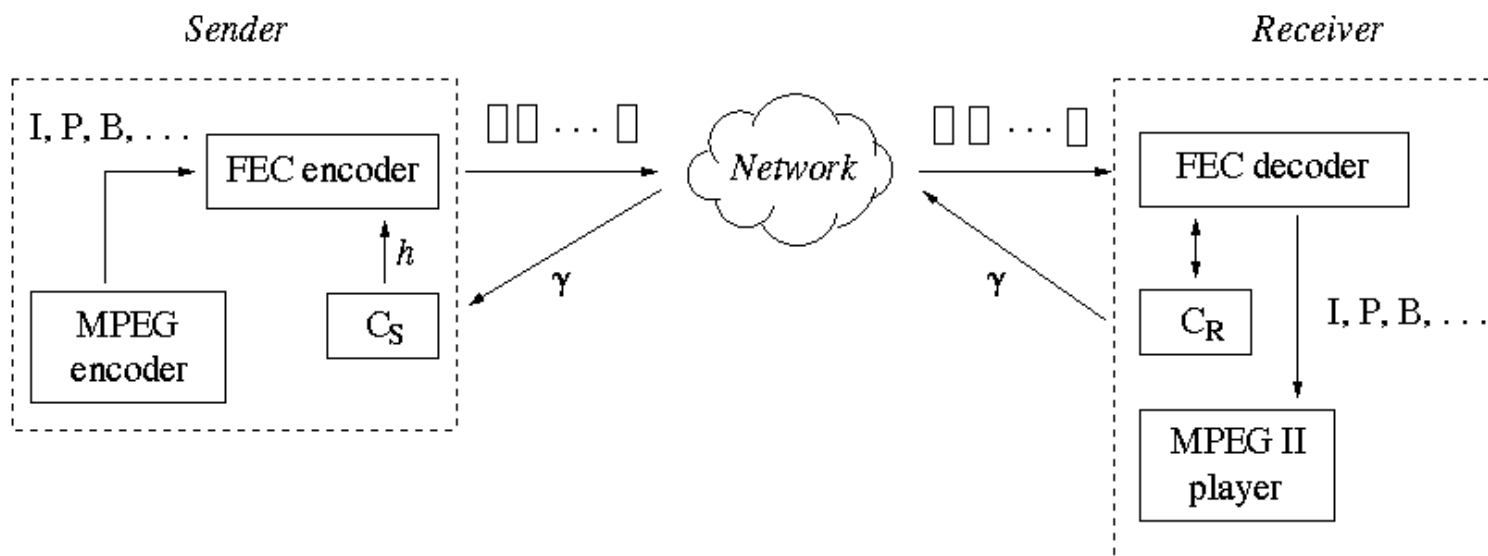

Adaptive Redundancy Control (cont.)

◆ Experimental set-up:

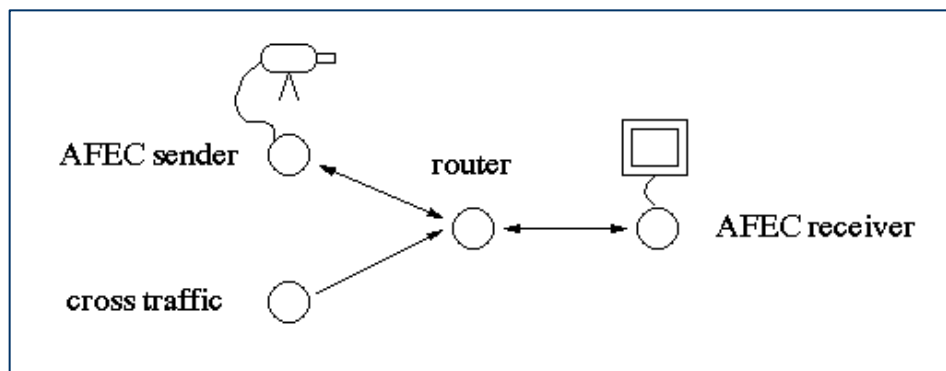

- UltraSparc 1 & 2, SGI, x86
- Solaris UNIX, Windows NT
- Optibase, Futuretel MPEG I & II compression boards
- Sony DCR-VX 1000, Panasonic F250

Adaptive Redundancy Control (cont.)

- ◆ Impact of redundancy: Static FEC

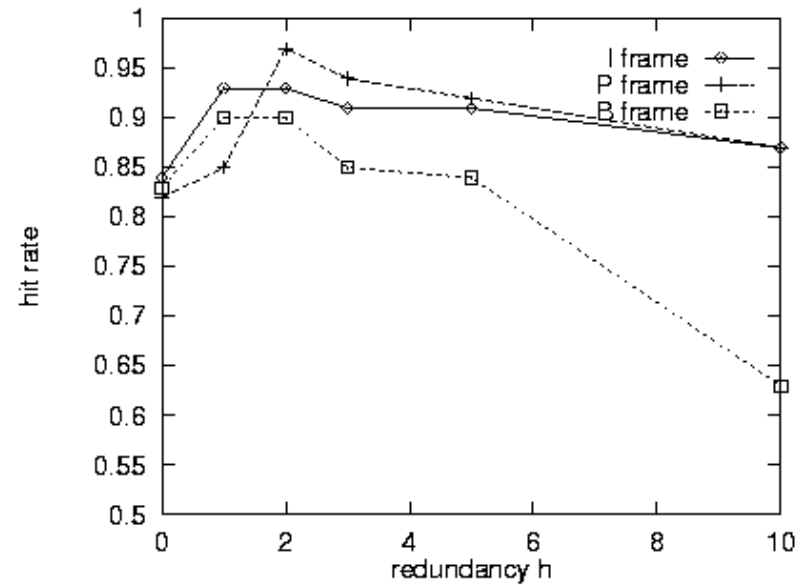
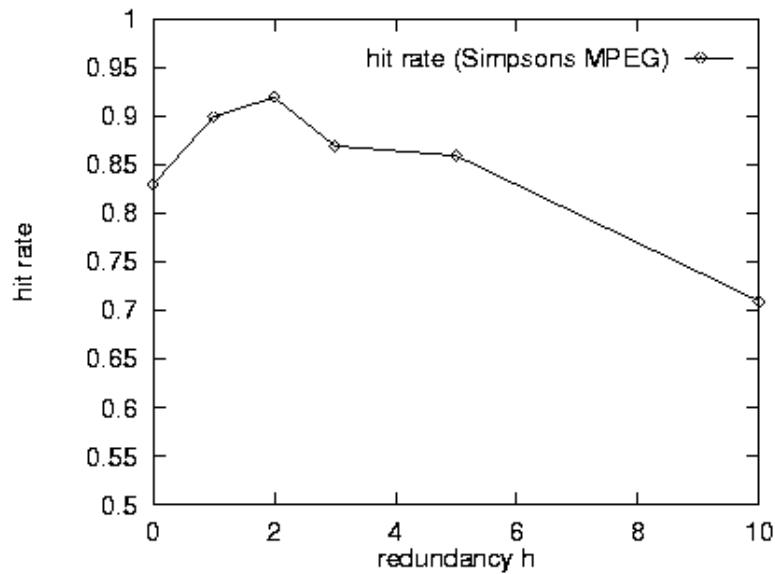

Adaptive Redundancy Control (cont.)

- ◆ Adaptive FEC vs. static FEC

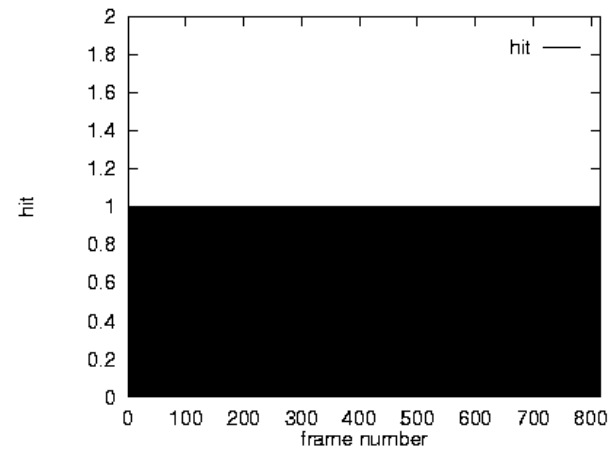
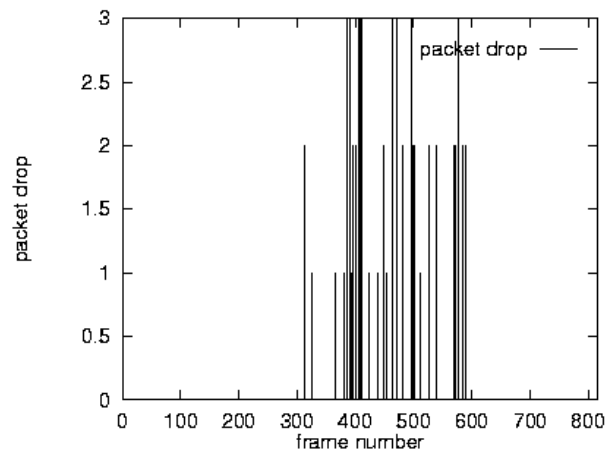
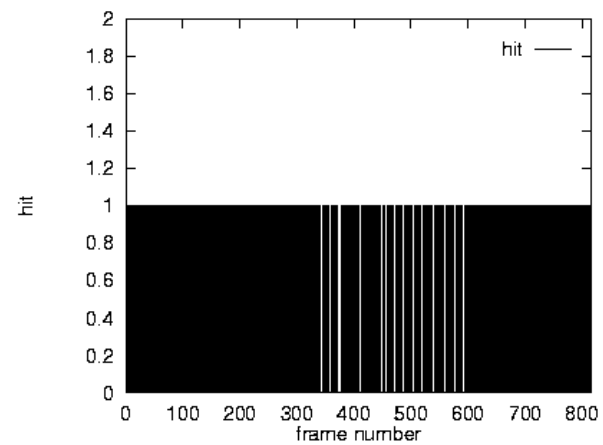
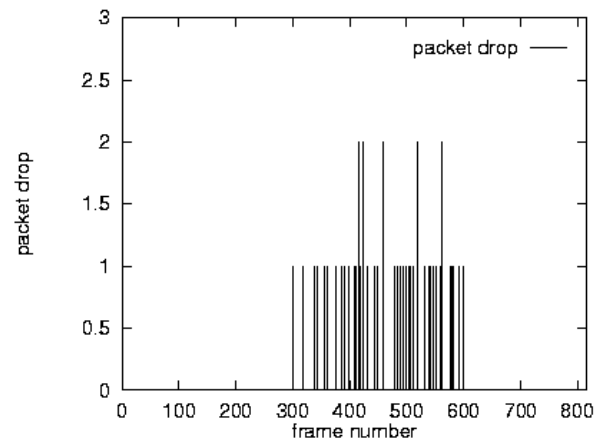

Adaptive Redundancy Control (cont.)

- ◆ Stable target QoS: symmetric control

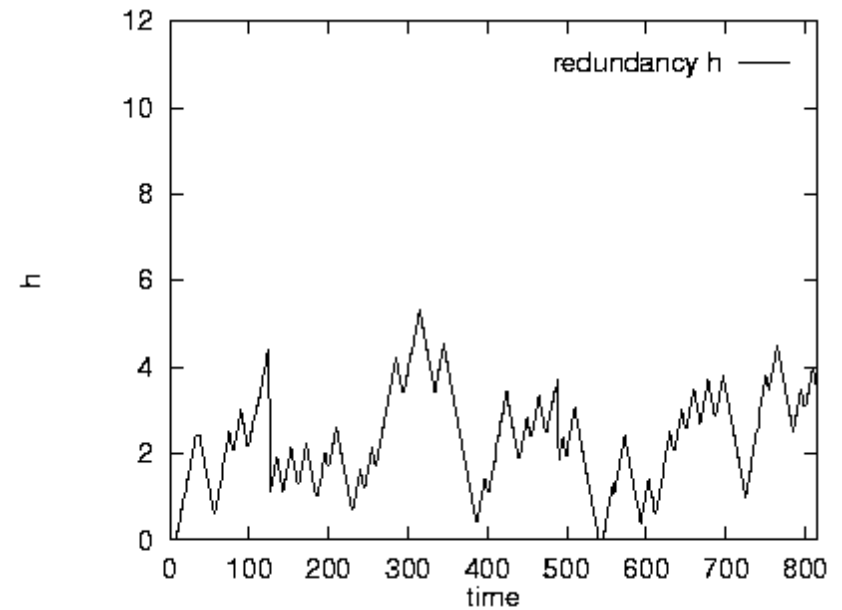
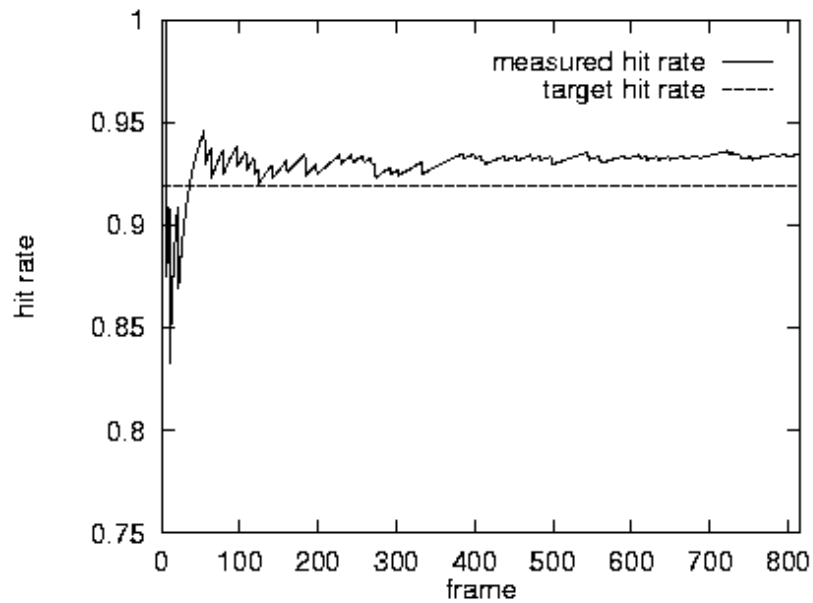

Adaptive Redundancy Control (cont.)

- ◆ Unstable target QoS: asymmetric control

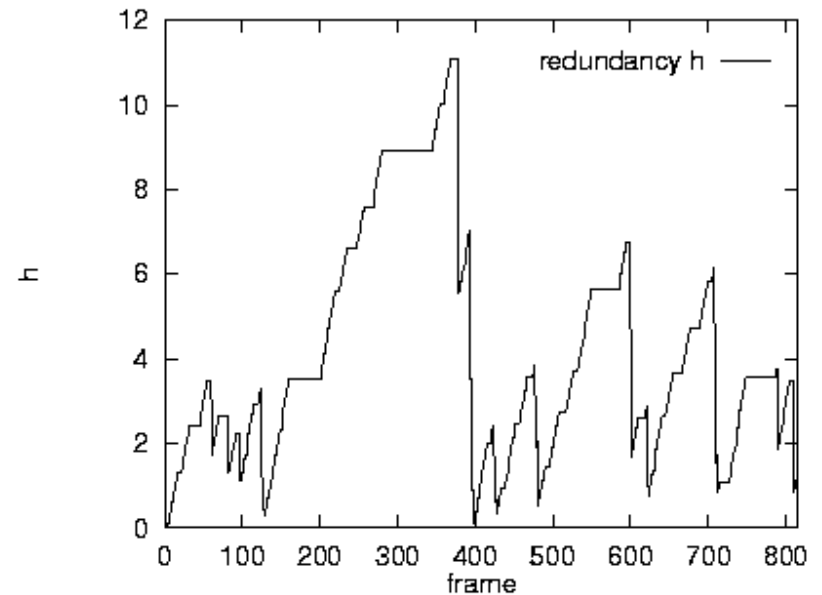
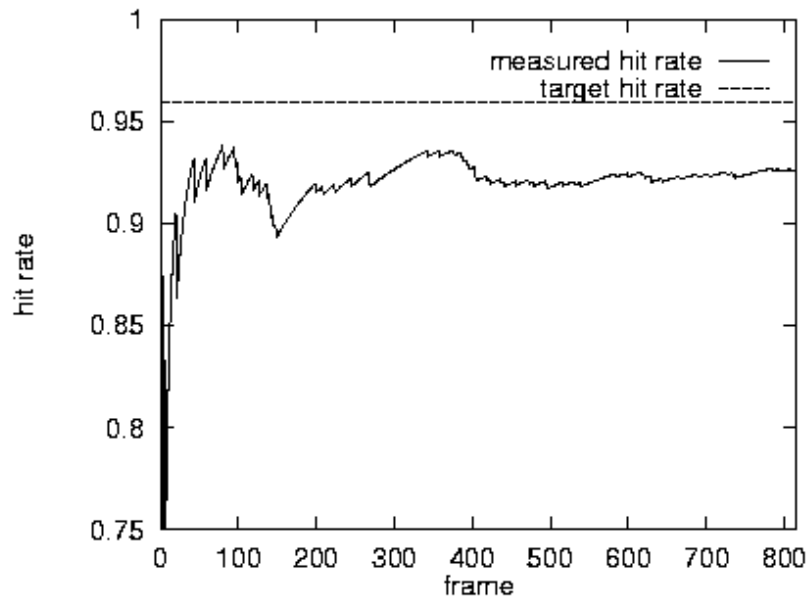

Adaptive Redundancy Control (cont.)

- ◆ Multiple time scale redundancy control

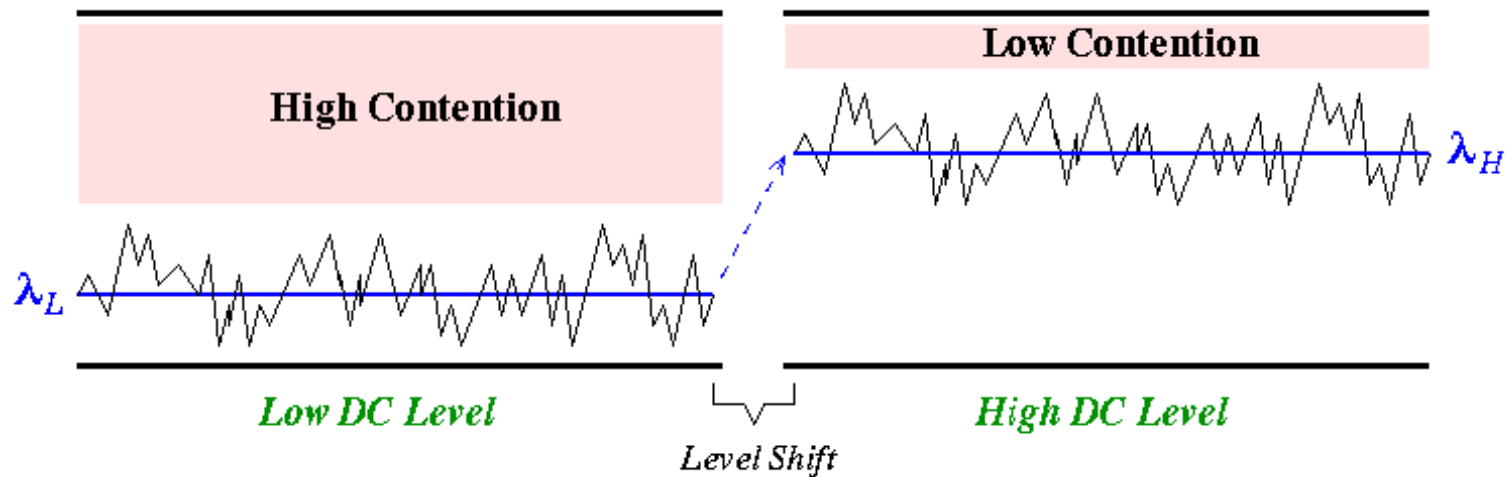

→ level control

Adaptive Redundancy Control (cont.)

- ◆ AFEC-MT structure:

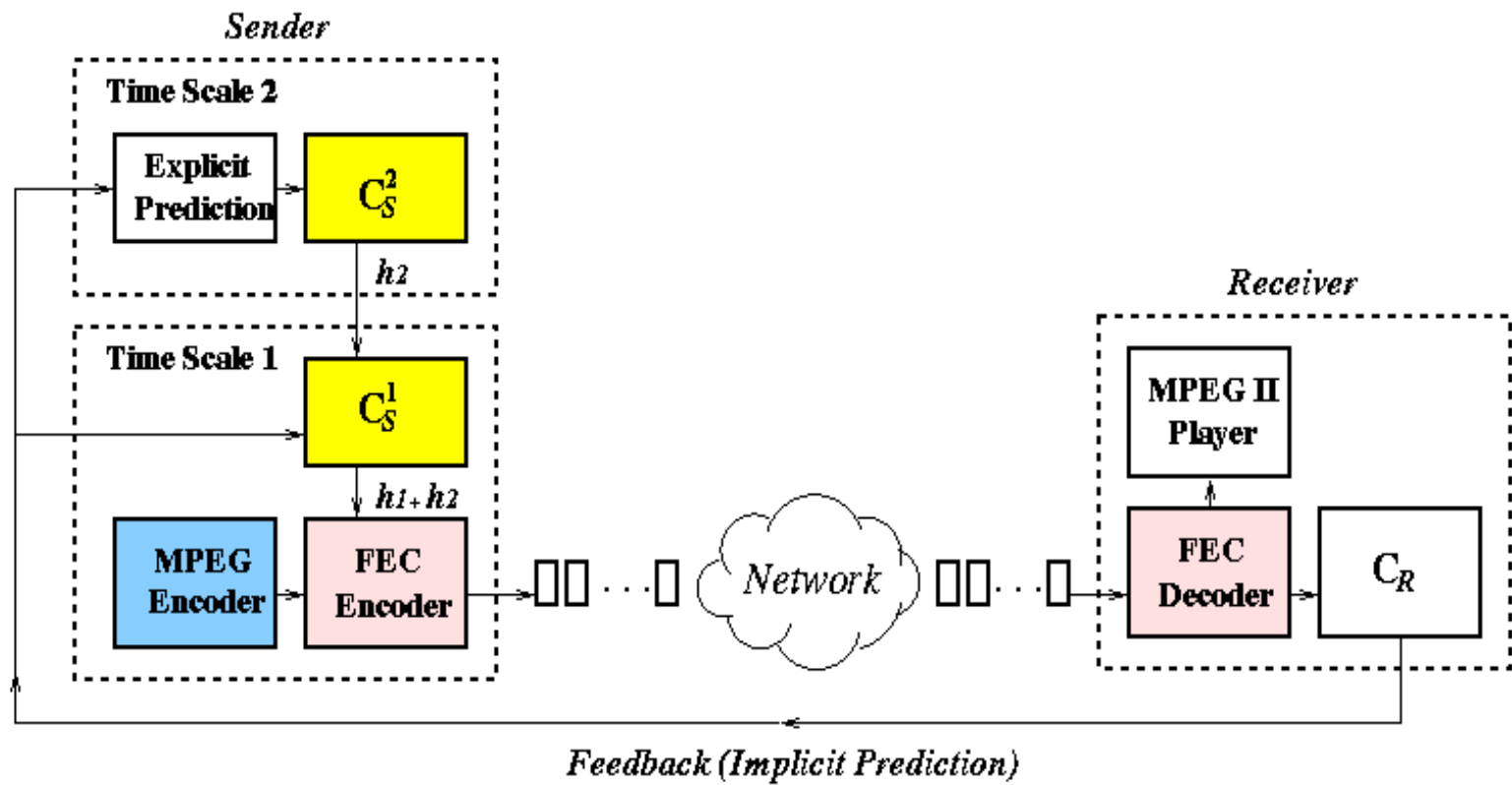

Adaptive Redundancy Control (cont.)

- ◆ AFEC-MT:

hit trace:

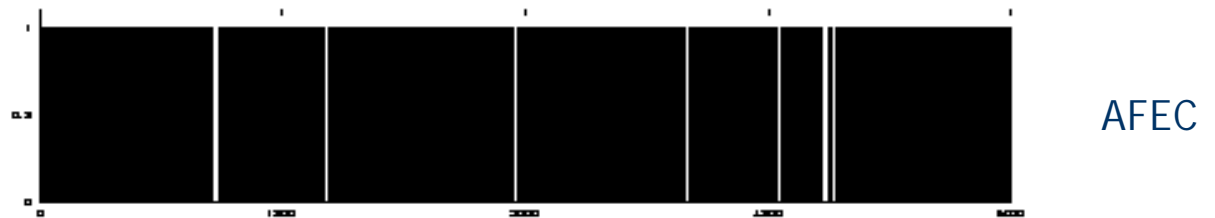

Adaptive Redundancy Control (cont.)

- ◆ Principal performance effect:
 - impart proactivity above and beyond AFEC
 - **proactivity** of reactive control in broadband WANs
 - mitigate reactive cost

predictability at time scales exceeding RTT imparts timeliness

Adaptive Label Control

Differentiated services network:

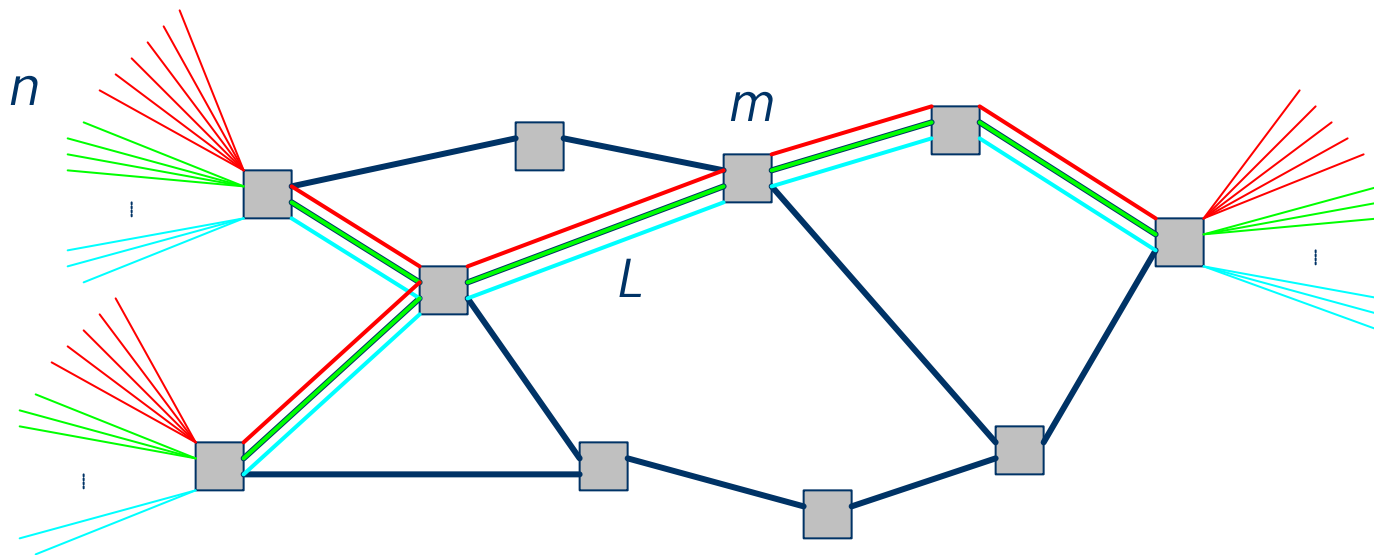

n users $\gg L$ labels (colors) $\geq m$ classes

Adaptive Label Control (cont.)

Questions:

- What is a “good” (optimal) per-hop control?
→ optimal aggregate-flow per-hop behavior



- What is a “good” (optimal) edge control?

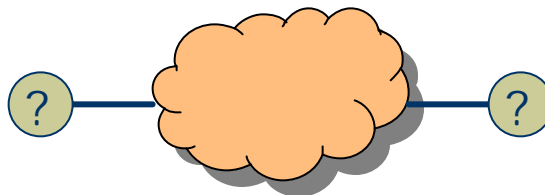

Adaptive Label Control (cont.)

- What is the loss of power due to aggregation?
 - $n \gg L \geq m$
 - loss of resolution vis-à-vis per-flow switching

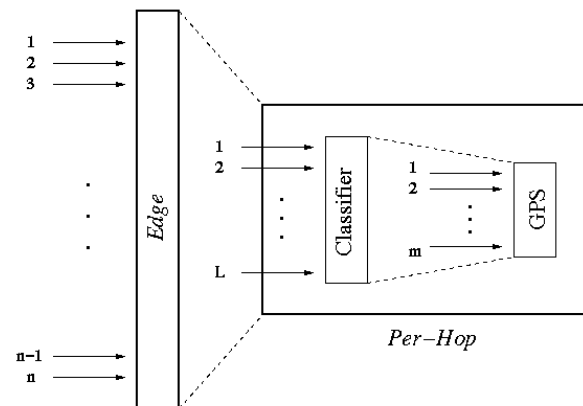

- What is the impact of finite, discrete label set $\{1, 2, \dots, L\}$?
 - $\eta \in \mathbf{Z}_+, \mathbf{R}_+, [0,1], \text{ or } \mathbf{R}_+^S$

Adaptive Label Control (cont.)

- What is the system dynamics when driven by selfish users?
 - end-to-end label control
 - stability (Nash equilibria) and efficiency (system optimality)

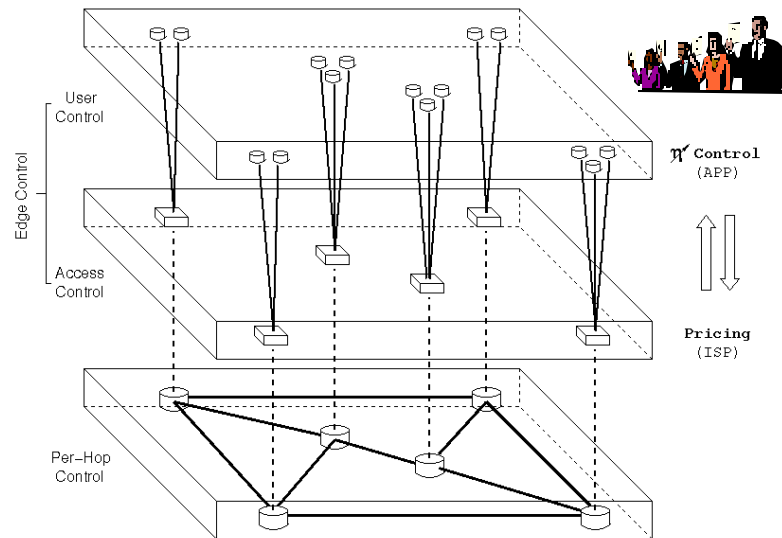

- What is the impact of selfish service provider (ISP)?



Adaptive Label Control (cont.)

Theory

- optimal PHB
 - differentiation/shaping
 - efficiency
- adaptive label control
- selfish users
- selfish service provider
- performance analysis

Simulation

QSim: WAN QoS Simulator

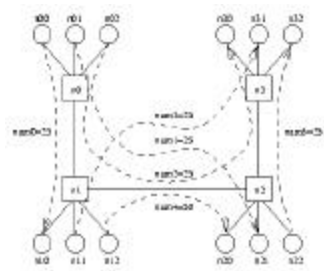
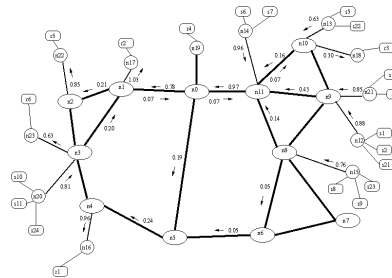

Implementation

Purdue Infobahn



Cisco 7206 VXR IP-over-SONET QoS Testbed

Adaptive Label Control (cont.)

Set-up:

- QSim: *ns* based WAN QoS simulation environment

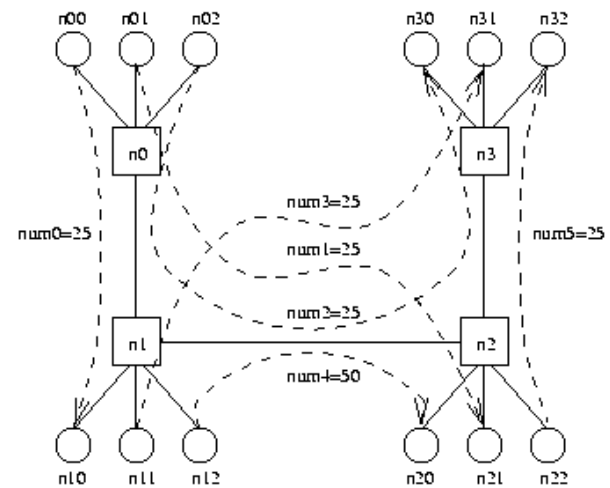
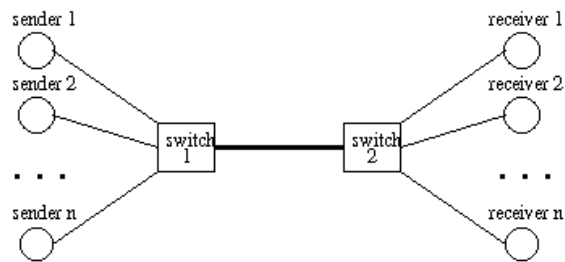

Adaptive Label Control (cont.)

- ◆ Structural: bottleneck BW, $L = 16$ ($m = 16$)

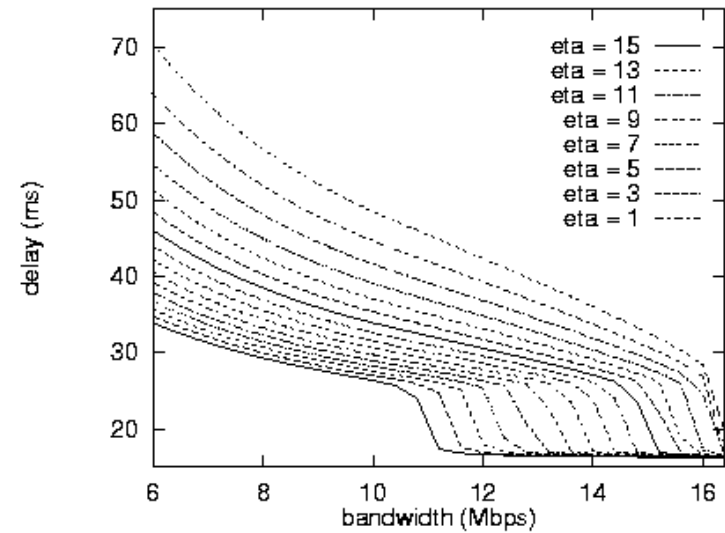
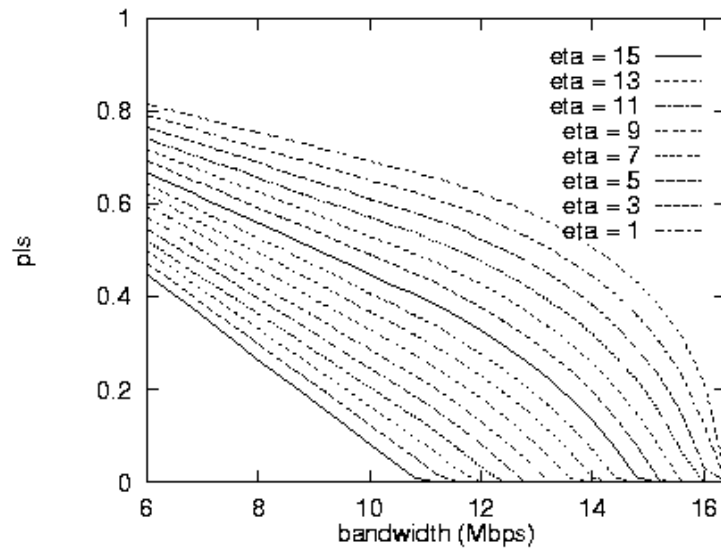

Adaptive Label Control (cont.)

- ◆ Structural: $L = 1, 4, 16, 32$

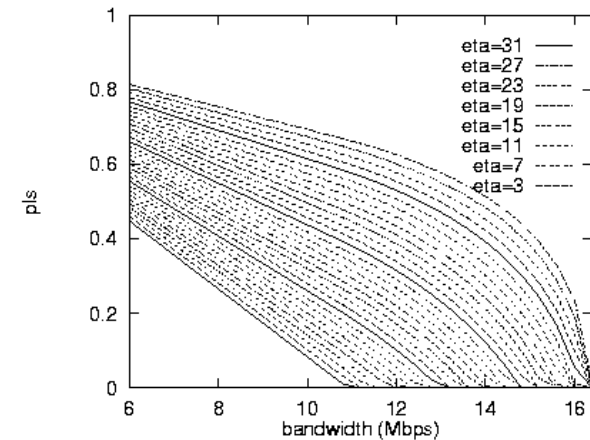
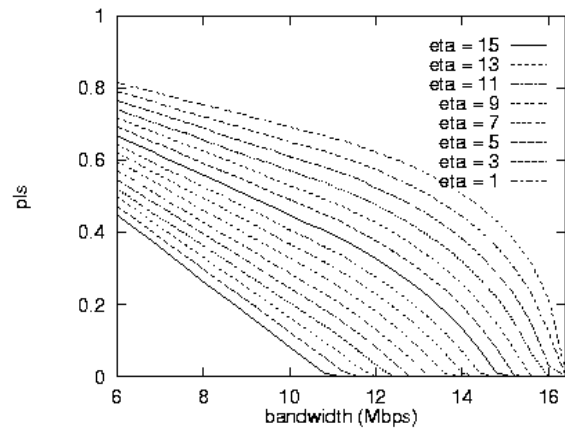
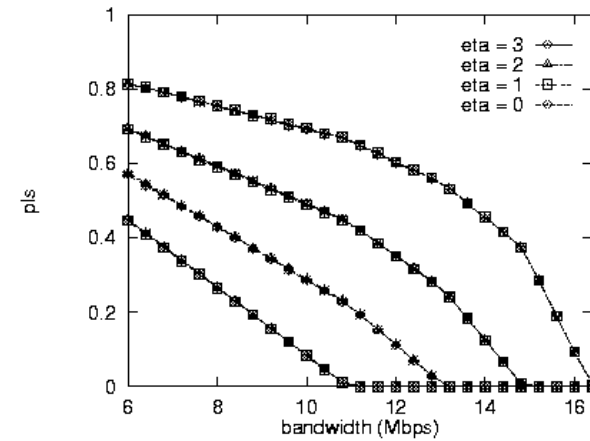
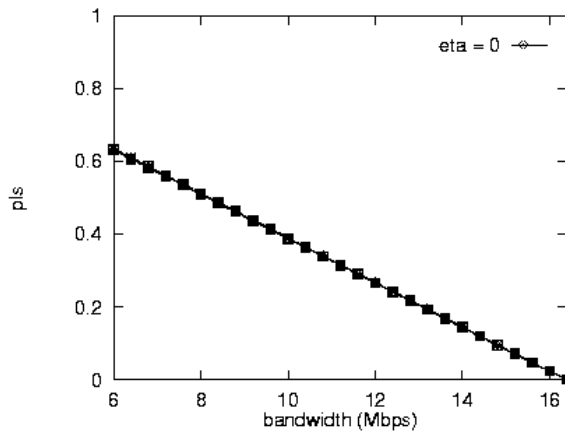

Adaptive Label Control (cont.)

- ◆ Structural: $\log L = 0, 1, 2, 3, 4, 5$ (bits)

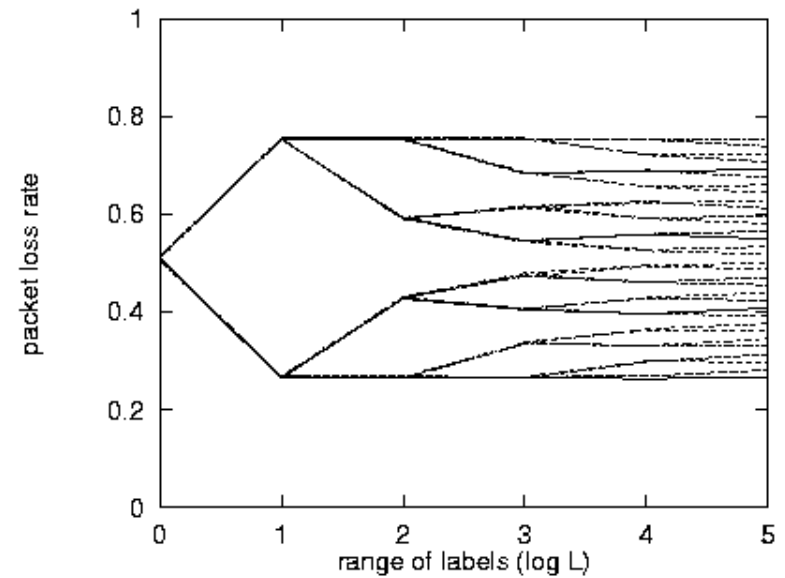
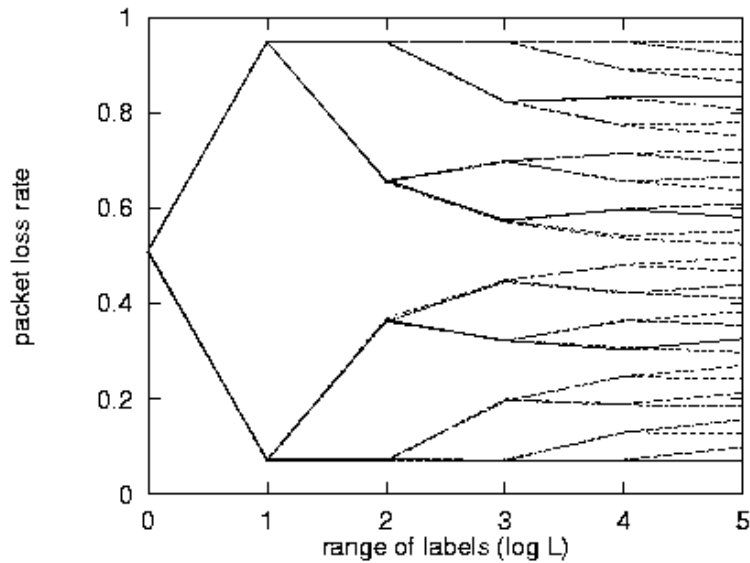

Adaptive Label Control (cont.)

- ◆ Structural: system optimal BW requirement

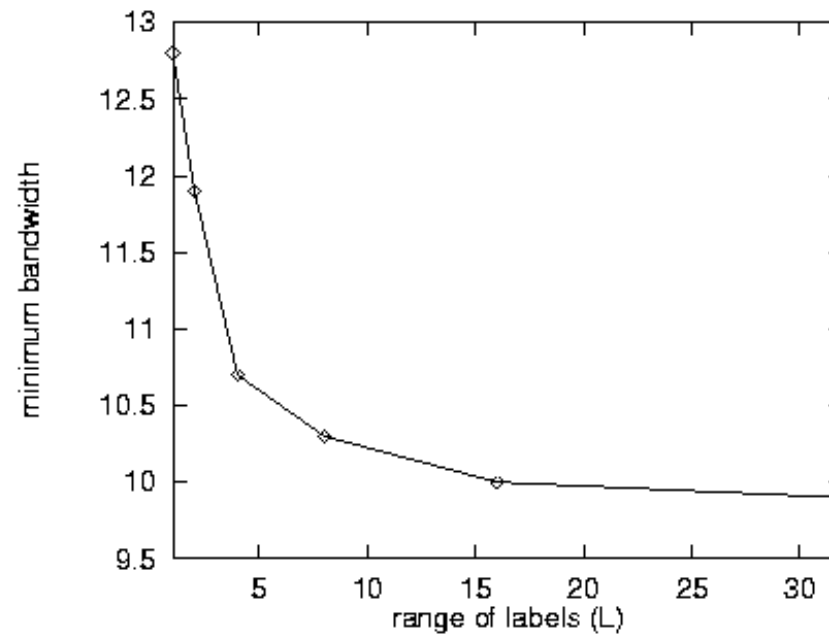

Adaptive Label Control (cont.)

- ◆ Dynamical: adaptive label control (end-to-end)
→ reachability

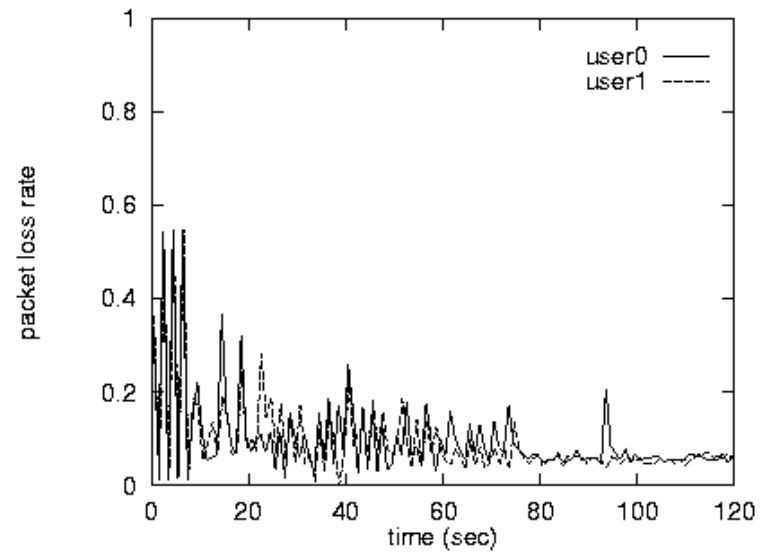
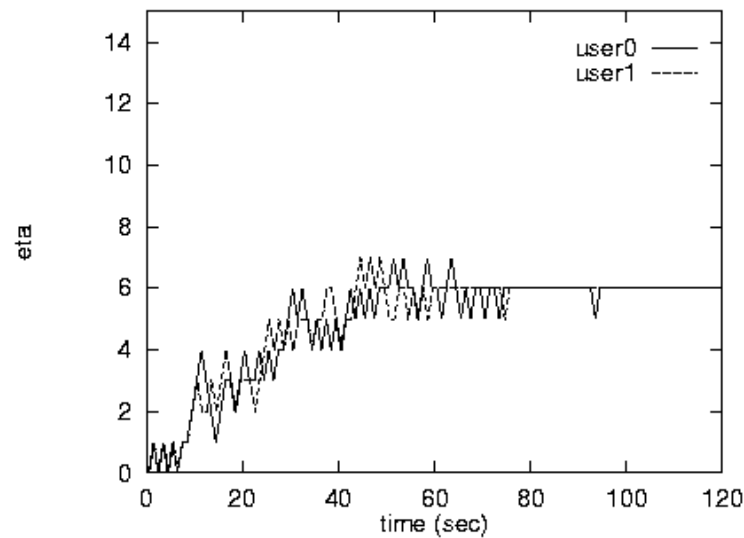

Adaptive Label Control (cont.)

- ◆ Dynamical: adaptive label control (cont.)

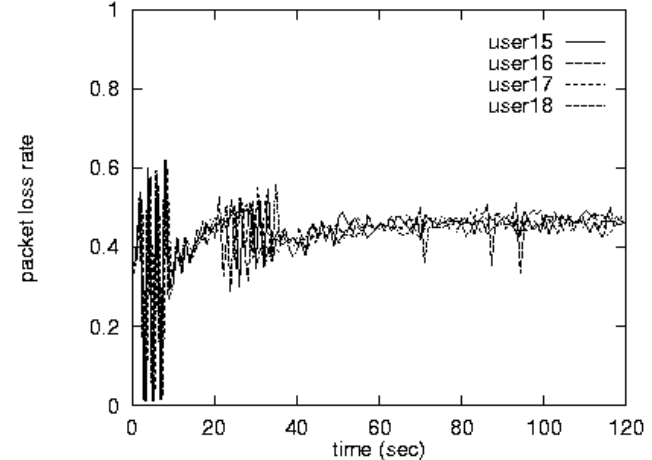
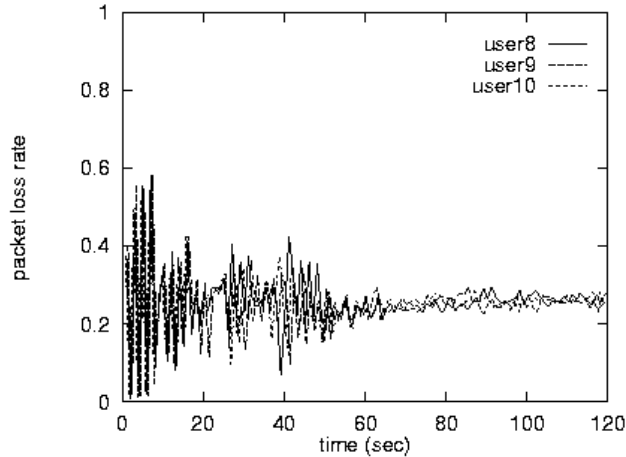
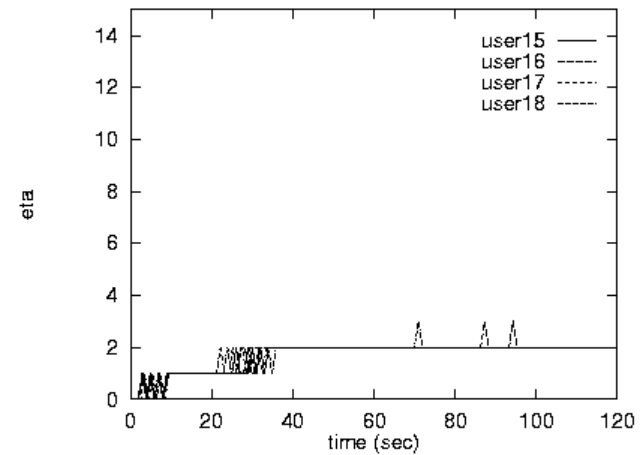
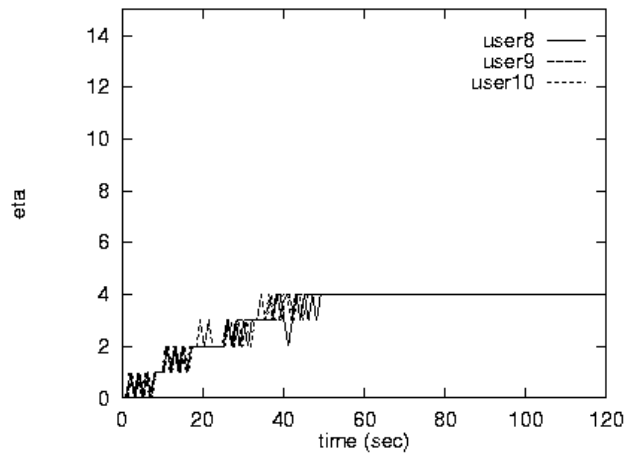

Adaptive Label Control (cont.)

Optimal aggregate-flow per-hop control:

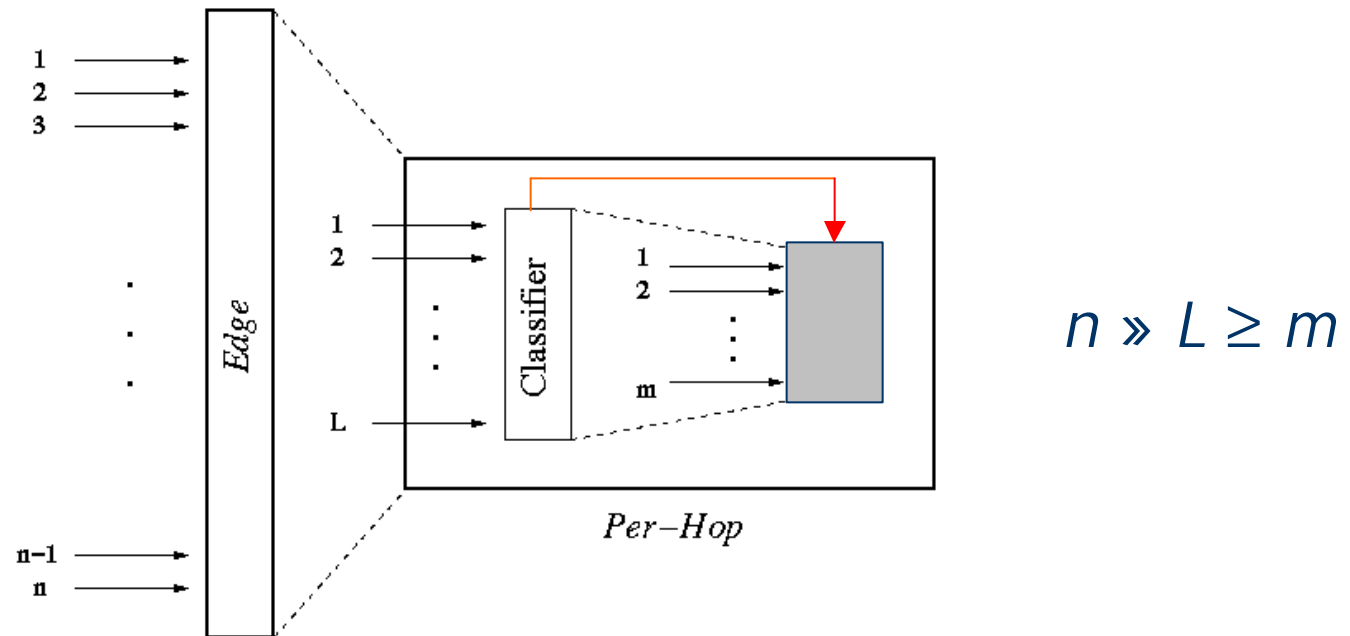

→ n users, L labels, and m service classes

Adaptive Label Control (cont.)

- ◆ Of interest: $n \gg L \geq m$
- ◆ Special case: $n = m$
 - per-flow per-hop control
- ◆ Of special interest: $L = m$
 - as many service classes as label values

Optimality I: service differentiation/shaping



Adaptive Label Control (cont.)

- ◆ Per-flow Control ($n = m$):
 - Label value η viewed as “code” of user requirement
 - e.g., 1.5 Mbps, relative share of link bandwidth, etc.
 - If infinite resources, then no interaction/coupling
 - e.g., INDEX
 - In resource-bounded systems, \exists coupling (externality)

Adaptive Label Control (cont.)

- ◆ Illustration of simple single switch case:

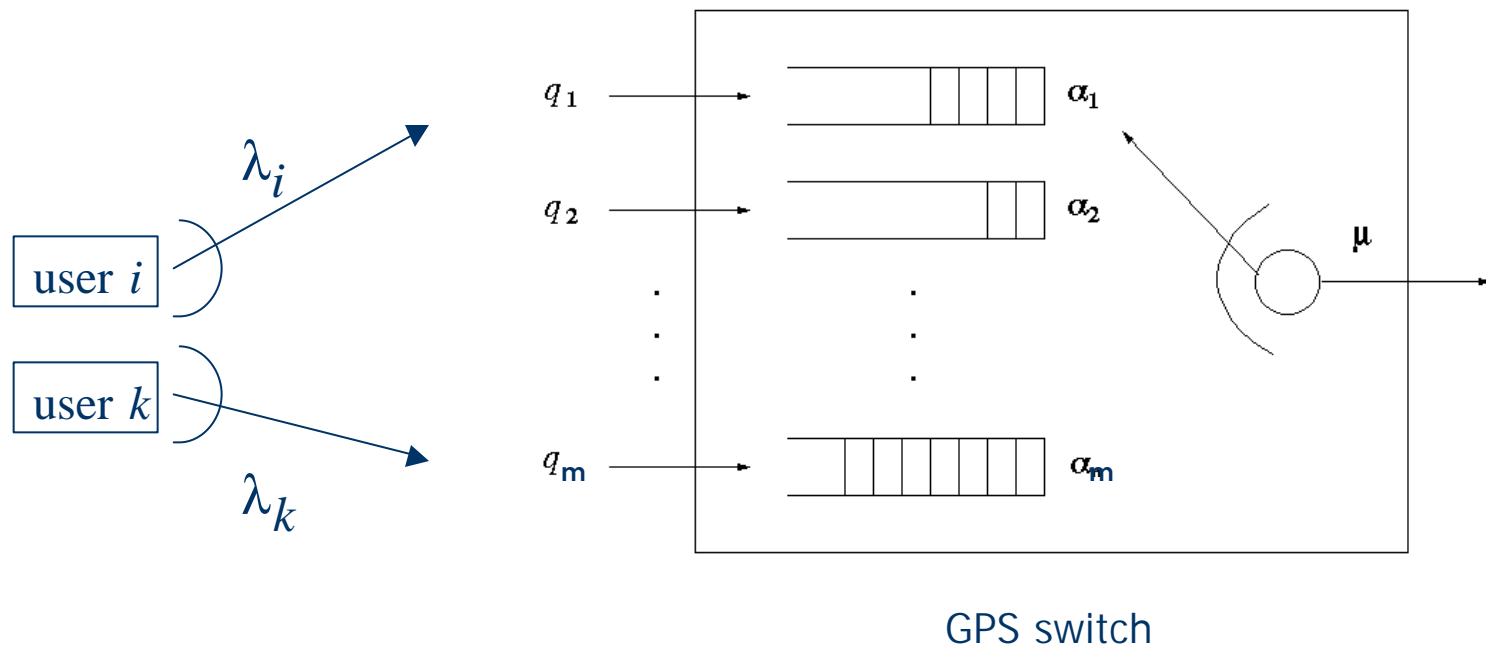

Adaptive Label Control (cont.)

- ◆ INDEX (Varaiya et al.)

<u>Platinum Service</u>	BW_1	$Price_1$
<u>Gold Service</u>	BW_2	$Price_2$
<u>Silver Service</u>	BW_3	$Price_3$
<u>Bronze Service</u>	BW_4	$Price_4$

- service class: volume insensitive
- infinite resources
- no externality

Adaptive Label Control (cont.)

- Assume label set is metric space (totally ordered)
 - e.g., Euclidean distance (L_2 norm)
 - e.g., $\eta = 1 < 2 < \dots < L$
- Mean square measure of goodness:

Given η , find resource configuration \mathbf{v} s.t.

$$\min_{\mathbf{v}} \sum_{i=1}^n (\mathbf{h}_i - \mathbf{v}_i)^2$$

Adaptive Label Control (cont.)

- ◆ GPS: $\varpi_i = \alpha_i / \lambda^i$

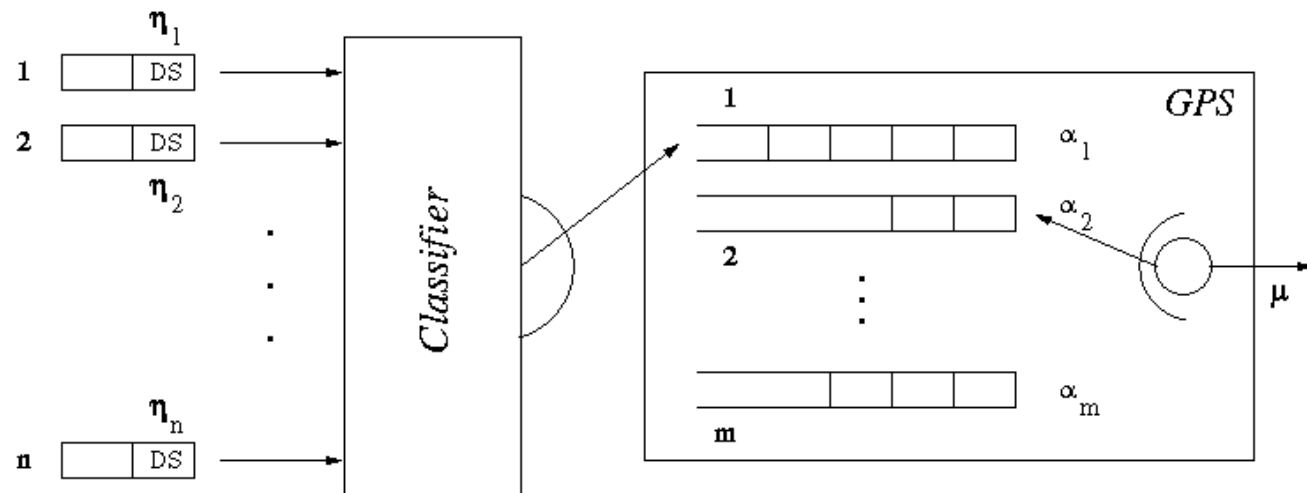

$$\eta_i \in \{1, 2, \dots, L\}; \quad \xi : \{1, \dots, L\} \rightarrow \{1, \dots, m\}$$

Adaptive Label Control (cont.)

◆ Normalization:
$$\frac{h_i - h_{\min}}{h_{\max} - h_{\min}} \in [0,1]$$

◆ Solution:
$$a_i = (1-u) \frac{l^i h^i}{\sum_k l^k h^k} + u \frac{l^i}{\sum_k l^k}$$

Adaptive Label Control (cont.)

- ◆ Optimal aggregate-flow classifier:

Given η , find resource configuration \mathbf{v} s.t.

$$\min_{\mathbf{v}} \sum_{i=1}^n (\mathbf{h}_i - \mathbf{v}_i)^2$$

- ◆ Optimal solution:

Reduce to per-flow optimal solution

→ optimal clustering problem

Adaptive Label Control (cont.)

- ◆ Properties (A1), (A2), and (B)
 - (A1) If η_i increases, then QoS of user i improves
 - (A2) If η_i increases, then QoS of user j degrades
 - (B) If $\eta_i \geq \eta_j$ then QoS of user i is better than QoS of user j
- ◆ Optimal per-flow classifier satisfies (A1), (A2), (B)
- ◆ Optimal aggregate-flow classifier with $L = m$ satisfies (A1), (A2), (B)

Adaptive Label Control (cont.)

- ◆ End-to-end QoS control:

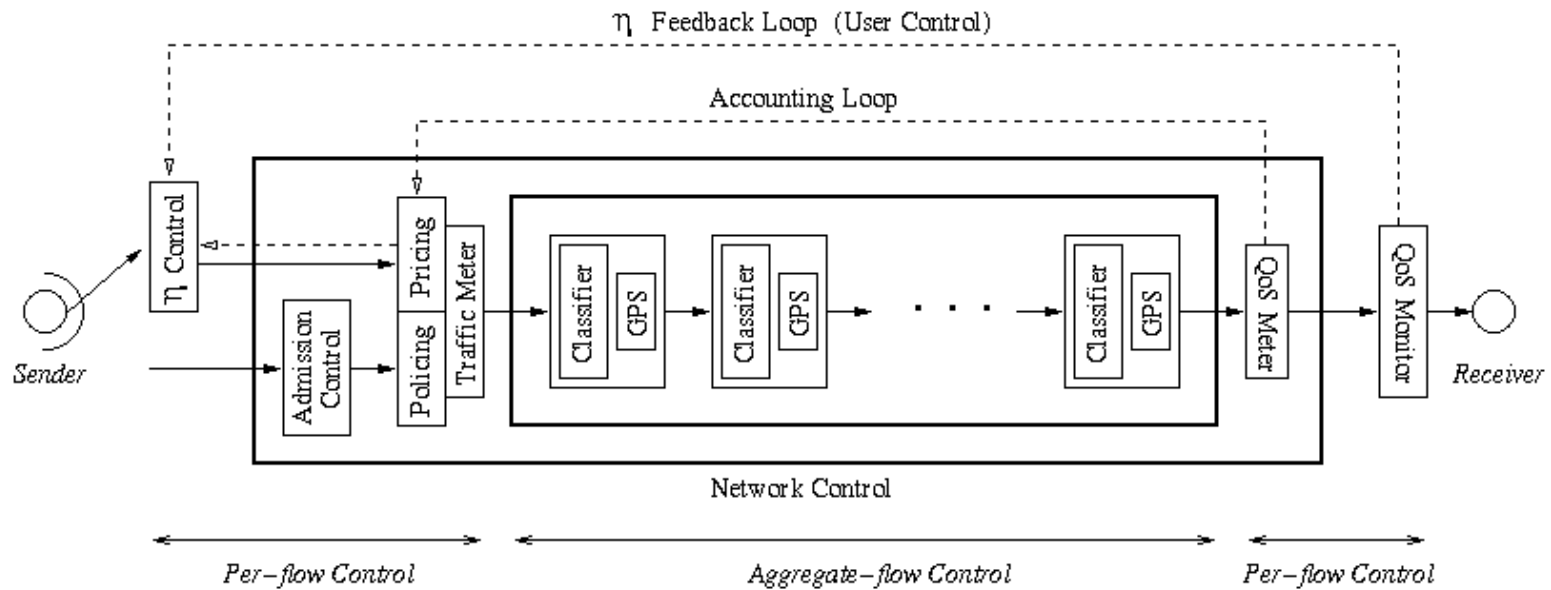

Adaptive Label Control (cont.)

- ◆ Integrated QoS control:
 - e.g., TCP over adaptive label control

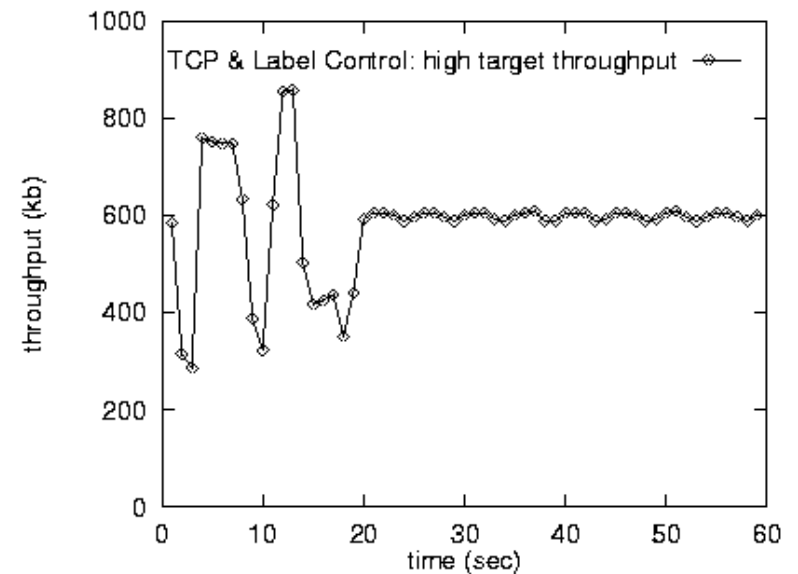
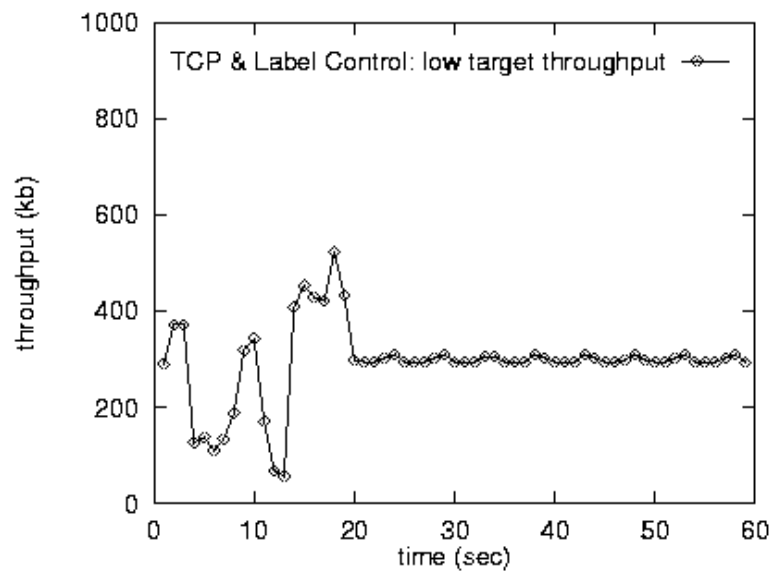



Local Environment: Network Systems Lab

- ◆ Purdue Infobahn QoS testbed: 4+5 Cisco 7206 VXR routers
 - IP-over-SONET backbone
 - custom classifier implementation in IOS
- ◆ NSF vBNS and Abilene connectivity (DS3)
 - Purdue vBNS/Internet2 Advisory Committee
- ◆ Fore ATM, FastEthernet switches
- ◆ Real-time MPEG I & II video/audio compression engines
 - Optibase, Futuretel (Windows NT)

Local Environment: NSL (cont.)

- ◆ Video/audio capture equipment
- ◆ 35+ Sun/Intel/SGI workstations & PCs
- ◆ Prototype software systems: UNIX, Windows NT

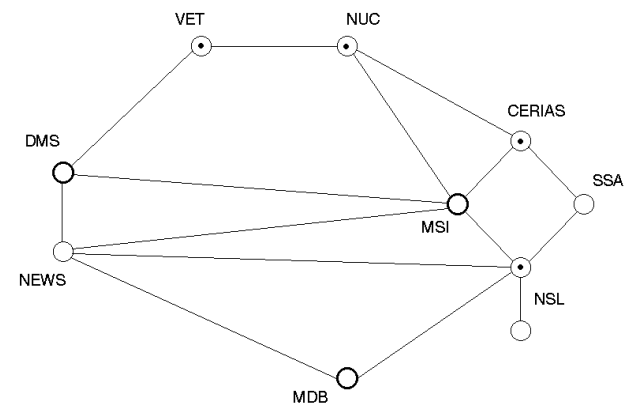



Proposed WAN Experiments

Performance Evaluation and Benchmarking

- ◆ Internet2 benchmarking of
 - Multiple time scale traffic control (TCP-MT, AFEC-MT)
 - Adaptive redundancy control (AFEC)
 - Adaptive label control (Diff-Serv router support)
 - vBNS/Abilene
- ◆ Commodity Internet benchmarking
- ◆ Evaluate effectiveness of end-to-end QoS amplification
 - model of future Internet (NGI)

Proposed WAN Experiments (cont.)

- ◆ Integration with Purdue Infobahn & QoS peering
- ◆ Pricing, accounting, and access control

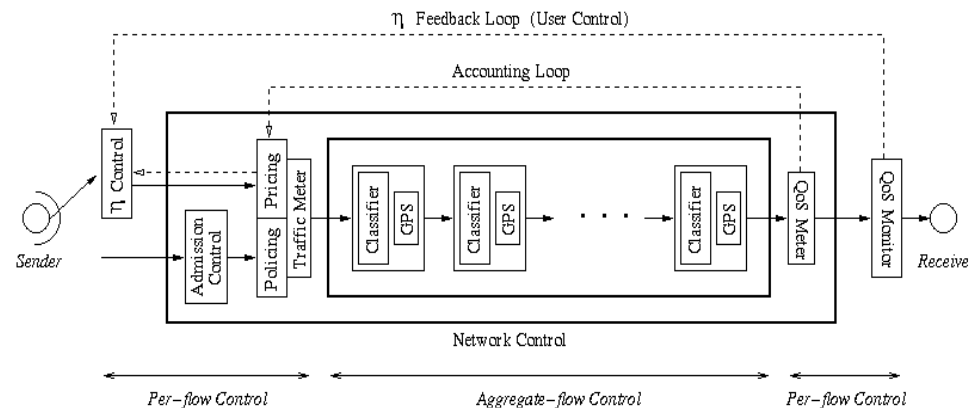

- ◆ Incremental optimal aggregate-flow classifier deployment (Cisco IOS)
- ◆ IP-over-ATM, IP-over-SONET, IP-over-? issues



Collaborations

◆ Academic:

- Boston Univ. (A. Bestavros)
- Ohio State Univ. (J. Hou)
- Santa Fe Institute (Fellow-at-Large)
- Univ. of Wisconsin (P. Barford; WAWM)
- Seoul National Univ. (S. Bahk)

◆ Industry/Research Labs:

- AT&T Research (W. Willinger)
- Cisco (F. Baker)
- Sprint (K. Metzger)



Internet2 Requirements

- ◆ Multi-point channel set-up, resource reservation
- ◆ Bottleneck configuration
- ◆ Congestion susceptibility
 - traffic generators and packet drops
- ◆ Diff-Serv support
- ◆ Network monitoring & management
- ◆ Modified router software deployment (partial)
- ◆ Member institution benchmark participation
 - scale

Acknowledgments & More Info

- ◆ Supported by:
 - NSF ANI-9714707, ANI-9875789 (CAREER), ESS-9806741, EIA-9972883; ANI-9729721 (vBNS)
 - Purdue Research Foundation
 - Santa Fe Institute
 - Sprint
 - CERIAS, SERC
- ◆ Research assistants & postdocs:
 - RAs: A. Balakrishnan, S. Chen, J. Cruz, G. Nalawade, H. Ren, M. Tripunitara, T. Tuan, W. Wang
 - Postdocs/visting scientists: S. Bahk, H. Lee, J. Park, W. Zhao
- ◆ Network Systems Lab
 - <http://www.cs.purdue.edu/nsf>

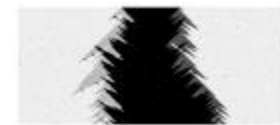

Acknowledgments & More Info (cont.)

◆ Recent publications:

- Chen & Park. An architecture for noncooperative QoS provision in many-switch systems. In *Proc. IEEE INFOCOM*, 1999.
- Cruz & Park. Towards performance-driven system support for distributed computing in clustered environments. *Journal of Parallel and Distributed Computing*, 1999.
- Park & Wang. QoS-sensitive transport of real-time MPEG video using adaptive forward error correction. In *Proc. IEEE Multimedia Systems*, 1999.
- Park & Willinger. *Self-Similar Network Traffic and Performance Evaluation*. Wiley-Interscience, 2000.
- Ren & Park. Toward a theory of differentiated services. In *Proc. IEEE/IFIP IWQoS*, 2000.
- Ren & Park. Efficient shaping of user-specified QoS using aggregate-flow control. In *Proc. International Workshop QoSIS*, Lectures Notes in Computer Science, 2000.
- Tuan & Park. Multiple time scale congestion control for self-similar network traffic. *Performance Evaluation*, 1999.
- Tuan & Park. Multiple time scale redundancy control for QoS-sensitive transport of real-time traffic. In *Proc. IEEE INFOCOM*, 2000
- Tuan & Park. Performance evaluation of multiple time scale TCP under self-similar traffic conditions. *ACM Trans. on Modeling and Computer Simulation*, 2000.